



*Singlewire-enabled  
VoIP V2 Loudspeaker  
Amplifier (PoE)  
Operations Guide*

Part #011116  
Document Part #930377B  
for Firmware Version 1.2.3

**CyberData Corporation**  
2555 Garden Road  
Monterey, CA 93940  
(831) 373-2601

---

**VoIP V2 Paging Amplifier Operations Guide 930377B**  
**Part # 011116**

**COPYRIGHT NOTICE:**

© 2010, CyberData Corporation, ALL RIGHTS RESERVED.

This manual and related materials are the copyrighted property of CyberData Corporation. No part of this manual or related materials may be reproduced or transmitted, in any form or by any means (except for internal use by licensed customers), without prior express written permission of CyberData Corporation. This manual, and the products, software, firmware, and/or hardware described in this manual are the property of CyberData Corporation, provided under the terms of an agreement between CyberData Corporation and recipient of this manual, and their use is subject to that agreement and its terms.

**DISCLAIMER:** Except as expressly and specifically stated in a written agreement executed by CyberData Corporation, CyberData Corporation makes no representation or warranty, express or implied, including any warranty or merchantability or fitness for any purpose, with respect to this manual or the products, software, firmware, and/or hardware described herein, and CyberData Corporation assumes no liability for damages or claims resulting from any use of this manual or such products, software, firmware, and/or hardware. CyberData Corporation reserves the right to make changes, without notice, to this manual and to any such product, software, firmware, and/or hardware.

**OPEN SOURCE STATEMENT:** Certain software components included in CyberData products are subject to the GNU General Public License (GPL) and Lesser GNU General Public License (LGPL) "open source" or "free software" licenses. Some of this Open Source Software may be owned by third parties. Open Source Software is not subject to the terms and conditions of the CyberData COPYRIGHT NOTICE or software licenses. Your right to copy, modify, and distribute any Open Source Software is determined by the terms of the GPL, LGPL, or third party, according to who licenses that software.

Software or firmware developed by CyberData that is unrelated to Open Source Software is copyrighted by CyberData, subject to the terms of CyberData licenses, and may not be copied, modified, reverse-engineered, or otherwise altered without explicit written permission from CyberData Corporation.

**TRADEMARK NOTICE:** CyberData Corporation and the CyberData Corporation logos are trademarks of CyberData Corporation. Other product names, trademarks, and service marks may be the trademarks or registered trademarks of their respective owners.



Phone: (831) 373-2601  
Technical Support Ext. 333  
support@cyberdata.net  
Fax: (831) 373-4193  
Company and product information at [www.cyberdata.net](http://www.cyberdata.net)

---

## Revision Information



Revision 930377B, released on 10-20-2010, corresponds to firmware version 1.2.3, and has the following changes:

- Adds [Section 2.2.2, "Loudspeaker Amplifier NEMA Box Components"](#).
- Adds [Section 2.2.3, "Connect the Loudspeaker Amplifier"](#).

---



# Important Safety Instructions

1. Read these instructions.
2. Keep these instructions.
3. Heed all warnings.
4. Follow all instructions.
5. Do not use this apparatus near water.
6. Clean only with dry cloth.
7. Do not block any ventilation openings. Install in accordance with the manufacturer's instructions.
8. Do not install near any heat sources such as radiators, heat registers, stoves, or other apparatus (including amplifiers) that produce heat.
9. Do not defeat the safety purpose of the polarized or grounding-type plug. A polarized plug has two blades with one wider than the other. A grounding type plug has two blades and a third grounding prong. The wide blade or the third prong are provided for your safety. If the provided plug does not fit into your outlet, consult an electrician for replacement of the obsolete outlet.
10. Protect the power cord from being walked on or pinched particularly at plugs, convenience receptacles, and the point where they exit from the apparatus.
11. Only use attachments/accessories specified by the manufacturer.
12. Refer all servicing to qualified service personnel. Servicing is required when the apparatus has been damaged in any way, such as power-supply cord or plug is damaged, liquid has been spilled or objects have fallen into the apparatus, the apparatus has been exposed to rain or moisture, does not operate normally, or has been dropped.
13. Prior to installation, consult local building and electrical code requirements.

 <p>GENERAL ALERT</p>	<p><b>Warning</b> <i>Electrical Hazard:</i> This product should be installed by a licensed electrician according to all local electrical and building codes.</p>
 <p>GENERAL ALERT</p>	<p><b>Warning</b> <i>Electrical Hazard:</i> To prevent injury, this apparatus must be securely attached to the floor/wall in accordance with the installation instructions.</p>

---

## Pictorial Alert Icons

	<p><b>General Alert</b></p> <p><i>This pictorial alert indicates a potentially hazardous situation. This alert will be followed by a hazard level heading and more specific information about the hazard.</i></p>
	<p><b>Ground</b></p> <p><i>This pictorial alert indicates the Earth grounding connection point.</i></p>

---

## Hazard Levels

**Danger:** Indicates an imminently hazardous situation which, if not avoided, will result in death or serious injury. This is limited to the most extreme situations.

**Warning:** Indicates a potentially hazardous situation which, if not avoided, could result in death or serious injury.

**Caution:** Indicates a potentially hazardous situation which, if not avoided, could result in minor or moderate injury. It may also alert users against unsafe practices.

**Notice:** Indicates a statement of company policy (that is, a safety policy or protection of property).

The safety guidelines for the equipment in this manual do not purport to address all the safety issues of the equipment. It is the responsibility of the user to establish appropriate safety, ergonomic, and health practices and determine the applicability of regulatory limitations prior to use. Potential safety hazards are identified in this manual through the use of words *Danger*, *Warning*, and *Caution*, the specific hazard type, and pictorial alert icons.

---

## Abbreviations and Terms

Abbreviation or Term	Definition
A-law	A standard companding algorithm, used in European digital communications systems to optimize, i.e., modify, the dynamic range of an analog signal for digitizing.
AVP	Audio Video Profile
Cat 5	TIA/EIA-568-B Category 5
DHCP	Dynamic Host Configuration Protocol
LAN	Local Area Network
LED	Light Emitting Diode
Mbps	Megabytes per Second.
NTP	Network Time Protocol
PBX	Private Branch Exchange
PoE	Power over Ethernet (as per IEEE 802.3af standard)
RTP	Real-time Transport Protocol
RTFM	Reset Test Function Management
SIP	Session Initiated Protocol
Talkback	Two-way communication enabled
TFTP	Trivial File Transfer Protocol
u-law	A companding algorithm, primarily used in the digital telecommunication
UC	Unified Communications
VoIP	Voice over Internet Protocol

# Contents

---

<b>Chapter 1 Product Overview</b>	<b>1</b>
1.1 How to Identify This Product .....	1
1.2 Typical System Installation .....	2
1.3 Product Features .....	3
1.4 Supported Protocols .....	3
1.5 Product Specifications .....	4
<b>Chapter 2 Installing the VoIP V2 Loudspeaker Amplifier</b>	<b>5</b>
2.1 Parts List .....	5
2.2 Loudspeaker Amplifier Setup .....	6
2.2.1 Loudspeaker Amplifier Components .....	7
2.2.2 Loudspeaker Amplifier NEMA Box Components .....	8
2.2.3 Connect the Loudspeaker Amplifier .....	9
2.2.4 Loudspeaker Amplifier DIP Switches .....	10
2.2.5 VoIP V2 Loudspeaker Amplifier System Installation and Connection Options .....	11
2.2.6 Confirm Operation .....	13
2.2.7 Confirm the IP Address and Test the Audio .....	14
2.2.8 Adjust the Volume .....	15
2.3 Configure the Loudspeaker Amplifier Parameters .....	16
2.3.1 Loudspeaker Amplifier Web Page Navigation .....	17
2.3.2 Log in to the Configuration Home Page .....	17
2.3.3 Upgrade the Firmware and Reboot the Loudspeaker Amplifier .....	20
2.3.4 Reboot the Loudspeaker Amplifier .....	23
2.4 Identifying and Testing a Loudspeaker Amplifier when Using InformaCast 4.0 or Later .....	24
<b>Appendix A Mounting the Amplifier</b>	<b>30</b>
A.1 Mount the Loudspeaker Amplifier .....	30
<b>Appendix B Setting up a TFTP Server</b>	<b>32</b>
B.1 Set up a TFTP Server .....	32
B.1.1 In a LINUX Environment .....	32
B.1.2 In a Windows Environment .....	32
<b>Appendix C Troubleshooting/Technical Support</b>	<b>33</b>
C.1 Frequently Asked Questions (FAQ) .....	33
C.2 Documentation .....	33
C.3 Contact Information .....	34
C.4 Warranty .....	34
C.4.1 Warranty & RMA Returns within the United States .....	35
C.4.2 Warranty & RMA Returns Outside of the United States .....	35
C.4.3 Spare in the Air Policy .....	35
C.4.4 Return and Restocking Policy .....	35
C.4.5 Warranty and RMA Returns Page .....	35
<b>Index</b>	<b>36</b>

# 1 Product Overview

The Singlewire-enabled VoIP V2 Loudspeaker Amplifier provides an easy method for implementing an IP-based overhead paging system for both new and legacy installations.

With up to 25 watts of driving power (802.3at), the Amplifier provides direct drive of a standard Horn speaker and supports a line-out connector for connection to an external amplifier. The interface is compatible with Singlewire's InformaCast software.

**Note** The version of InformaCast needs to be 4.0 or higher.

**Note** Prior to installation, create a plan for the locations of your units.

	<p>General Alert  <i>Consult local building and electrical code requirements prior to installation.</i></p>
---	---

## 1.1 How to Identify This Product

To identify the VoIP V2 Loudspeaker Amplifier, look for a model number label similar to the one shown in [Figure 1-1](#). The model number on the label should be **011116**.

Figure 1-1. Model Number Label

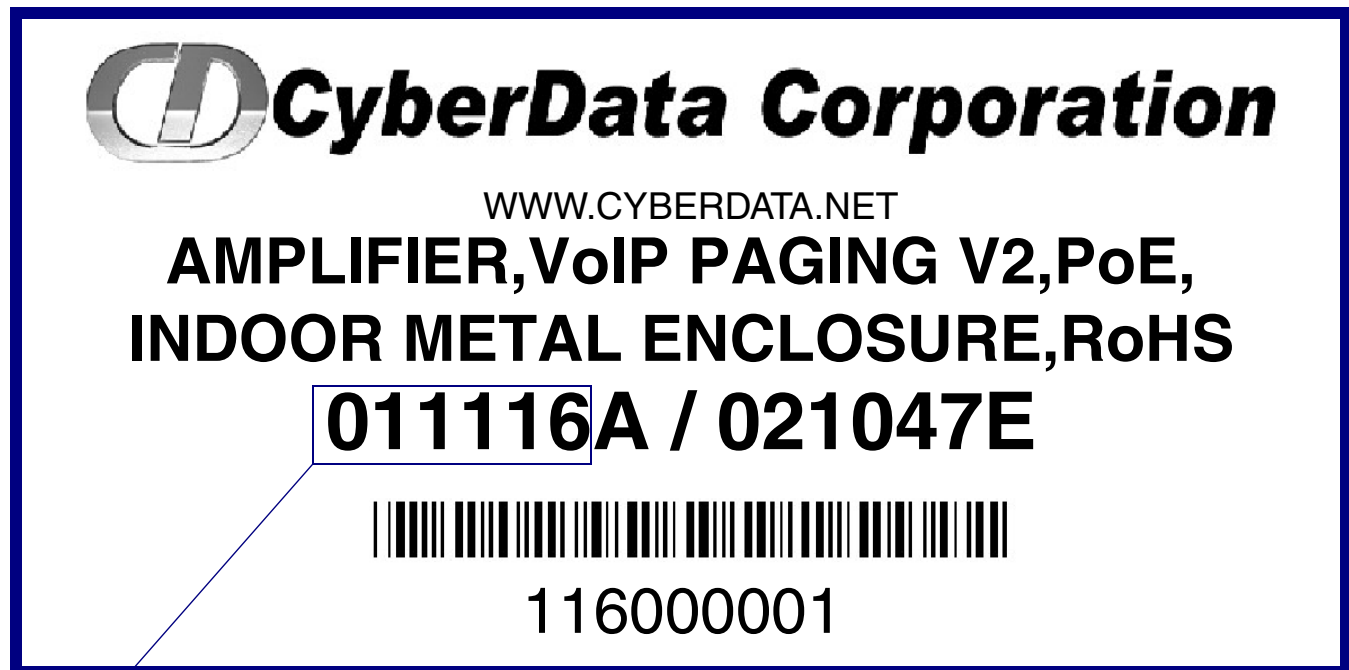

Model number



## 1.2 Typical System Installation

Figure 1-2 illustrates how the VoIP V2 Loudspeaker Amplifier is normally installed as part of a public address system.

Figure 1-2. Typical Installation

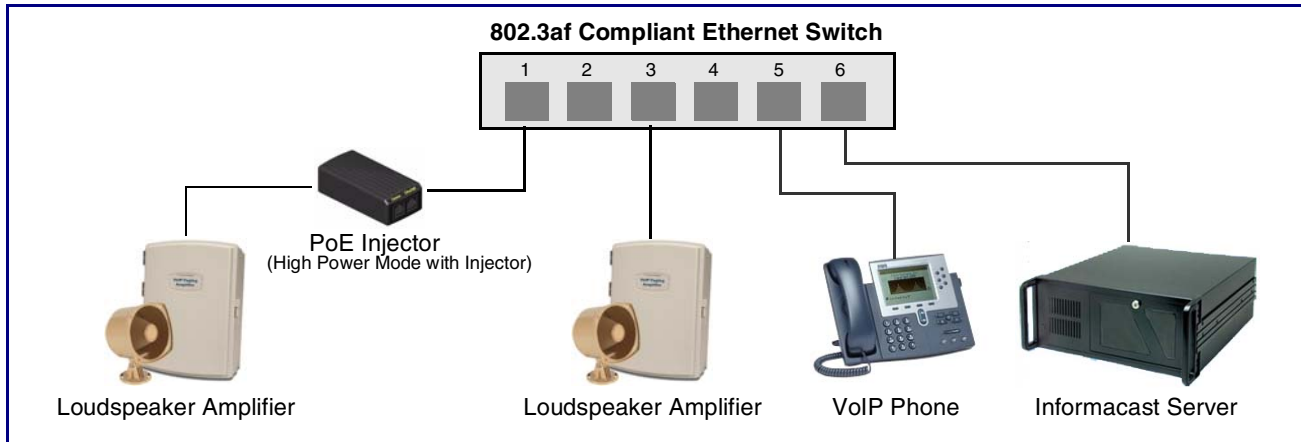

---

## 1.3 Product Features

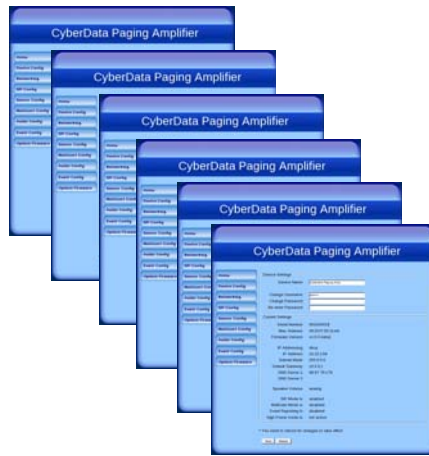

- InformaCast software compatible
- Dual-speed ethernet 10/100 Mbps
- Web-based configuration
- Web-based firmware upgradeable
- PoE 802.3af-enabled (Powered-over-Ethernet)
- Line-out connector
- Direct speaker drive
- Network and external speaker volume control

---

## 1.4 Supported Protocols

The Loudspeaker Amplifier supports:

- HTTP Web-based configuration  
Provides an intuitive user interface for easy system configuration and verification of Loudspeaker Amplifier operations.
- DHCP Client  
Dynamically assigns IP addresses in addition to the option to use static addressing.
- TFTP Client  
Facilitates Web-based firmware upgrades of the latest Loudspeaker Amplifier capabilities.
- RTP
- RTP/AVP - Audio Video Profile
- SPEEX
- Audio Encodings  
PCMU (G.711 mu-law)  
PCMA (G.711 A-law)  
Packet Time 20 ms

## 1.5 Product Specifications

**Table 1. Product Specifications**





Category	Specification
Ethernet I/F	10/100 Mbps
Power Input	PoE 802.3at or 802.3af
Operating Temperature	-30 to 55 C (-22 to 131 F)
Protocol	SIP RFC 3261
Payload Types	G711, SPEEX
Regulatory Compliance	FCC Class A, CE
Warranty	2 Years Limited
Dimensions	1.26" x 9.45" x 3.13"
Audio Output	802.3af - up to 10 Watts (default, 50% duty cycle [one second on and one second off]).
Lineout:	
Output Signal Amplitudes	2.0 VPP maximum
Output Level	+2dBm nominal
Total Harmonic Distortion	0.5% maximum
Part Number	011116

# 2 Installing the VoIP V2 Loudspeaker Amplifier

## 2.1 Parts List

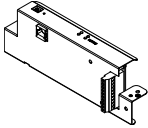
Table 2-1 illustrates the parts for each Loudspeaker Amplifier and includes a kit for mounting.

**Table 2-1. Parts List**

Quantity	Part Name	Illustration
1	Loudspeaker Amplifier Assembly	
1	Enclosure	
1	Installation Quick Reference Guide	
1	Loudspeaker Amplifier Mounting Accessory Kit, RoHS (part #071057A) which includes: (3) Plastic Ribbed Anchors (3) #6 Sheet Metal Screws	

---

## 2.2 Loudspeaker Amplifier Setup

Set up and configure each Loudspeaker Amplifier *before* you mount it.

CyberData delivers each Loudspeaker Amplifier with the factory default values indicated in [Table 2-2](#):

**Table 2-2. Factory Default Settings—Default of Network**

Parameter	Factory Default Setting
IP Addressing	DHCP
IP Address <sup>a</sup>	10.10.10.10
Web Access Username	admin
Web Access Password	admin
Subnet Mask <sup>a</sup>	255.0.0.0
Default Gateway <sup>a</sup>	10.0.0.1

a. Default if there is not a DHCP server present.

## 2.2.1 Loudspeaker Amplifier Components

Figure 2-3 shows the components of the Loudspeaker Amplifier .

Figure 2-3. Loudspeaker Amplifier Components

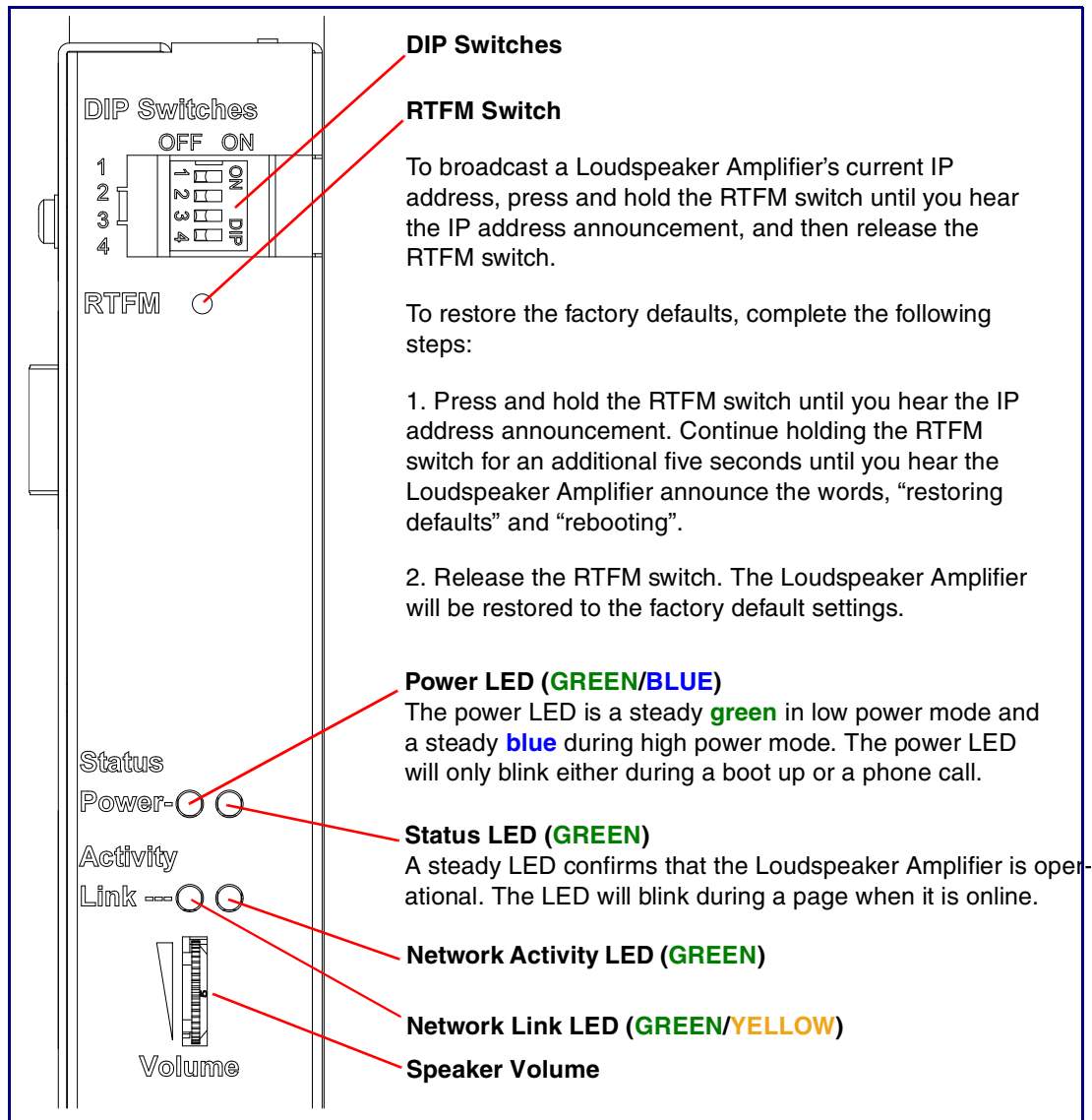

## 2.2.2 Loudspeaker Amplifier NEMA Box Components

Figure 2-4 shows all of the NEMA box components of the loudspeaker amplifier.

**Figure 2-4. Loudspeaker Amplifier Components—AC powered**

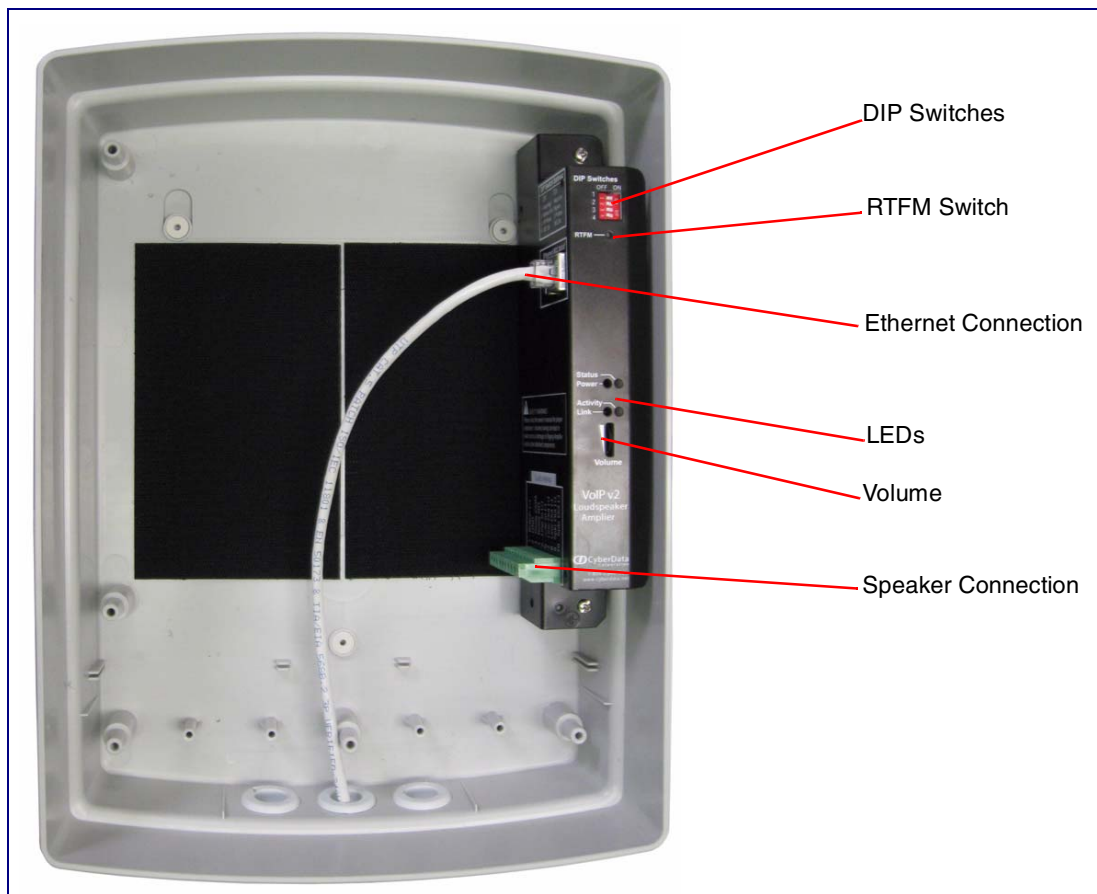

### 2.2.3 Connect the Loudspeaker Amplifier

Figure 2-5 illustrates how to connect the VoIP V2 Loudspeaker Amplifier via a Cat 5 Ethernet Cable.

Figure 2-5. Connect a Loudspeaker

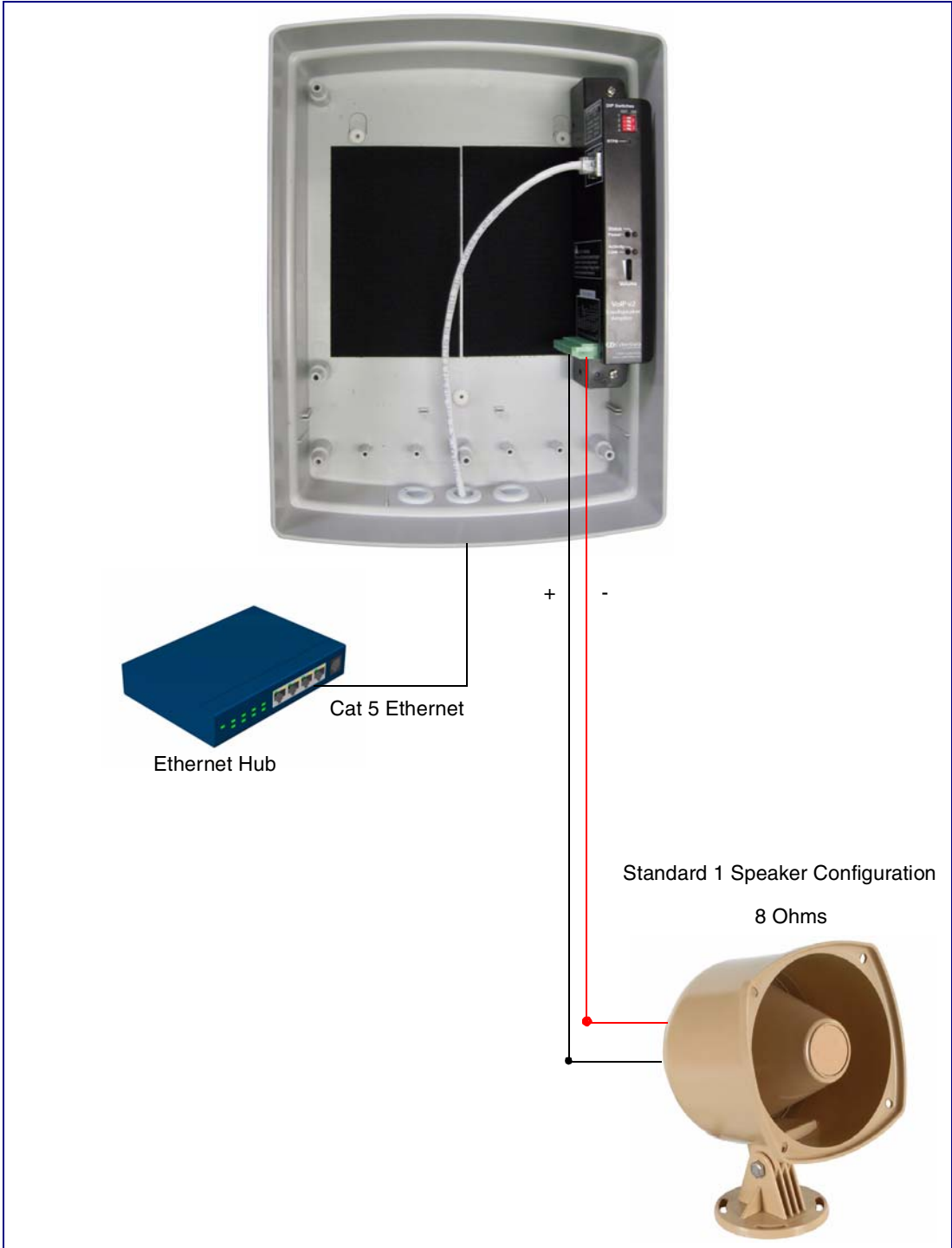



## 2.2.4 Loudspeaker Amplifier DIP Switches

See [Figure 2-6](#) to identify the DIP Switches.

**Figure 2-6. DIP Switches**

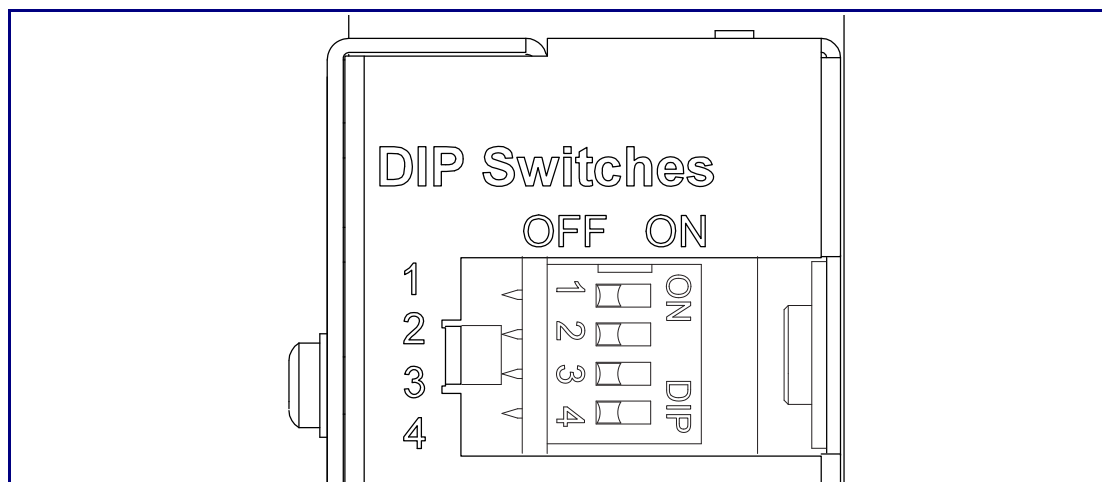

See [Table 2-3](#) for the DIP Switch settings for the revision B (or later) board.

**Table 2-3. DIP Switch Settings—Low Power—802.3af Compliant (Default)**

DIP Switch	Setting	Description
1	OFF	Sets PoE for 802.3af class.
2	N/A	Not applicable for power setting.
3	ON	Switch mode current set to <b>LOW</b> .
4	OFF	Low gain amplifier setting.

## 2.2.5 VoIP V2 Loudspeaker Amplifier System Installation and Connection Options

Figure 2-7 through Figure 2-8 illustrates connection options for the VoIP V2 Loudspeaker Amplifier.

**Figure 2-7. V2 Paging Amplifier Connections**

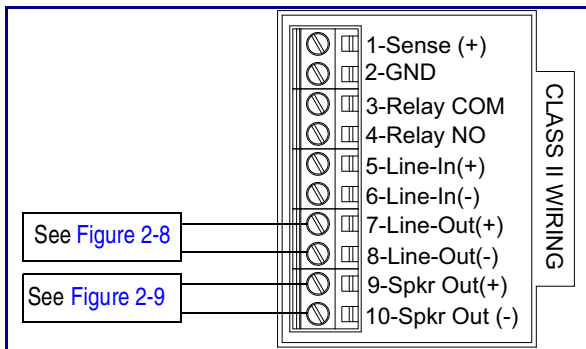

**Figure 2-8. Line Out Connection**

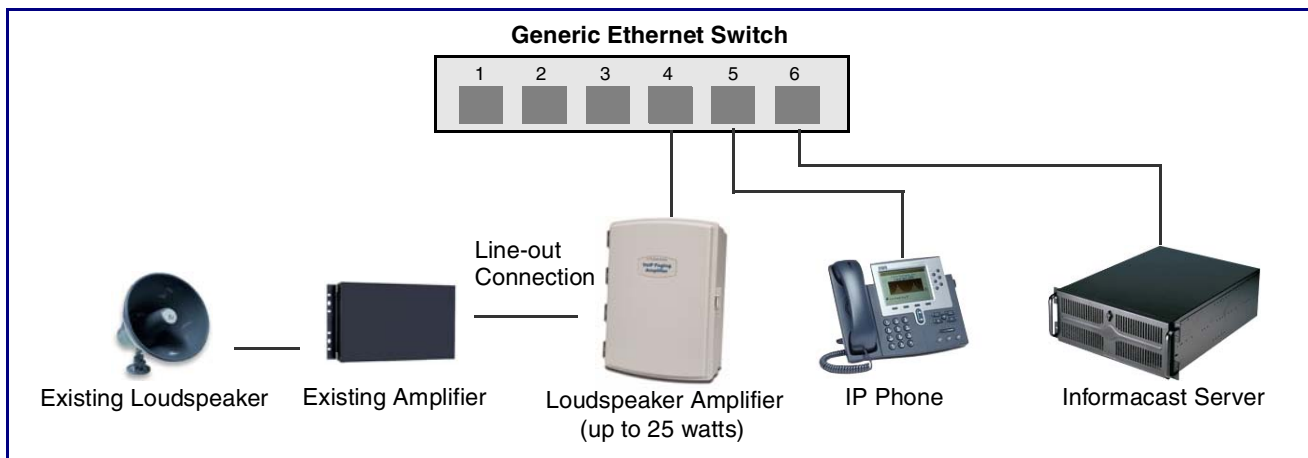

**Figure 2-9. Speaker Out Connection**

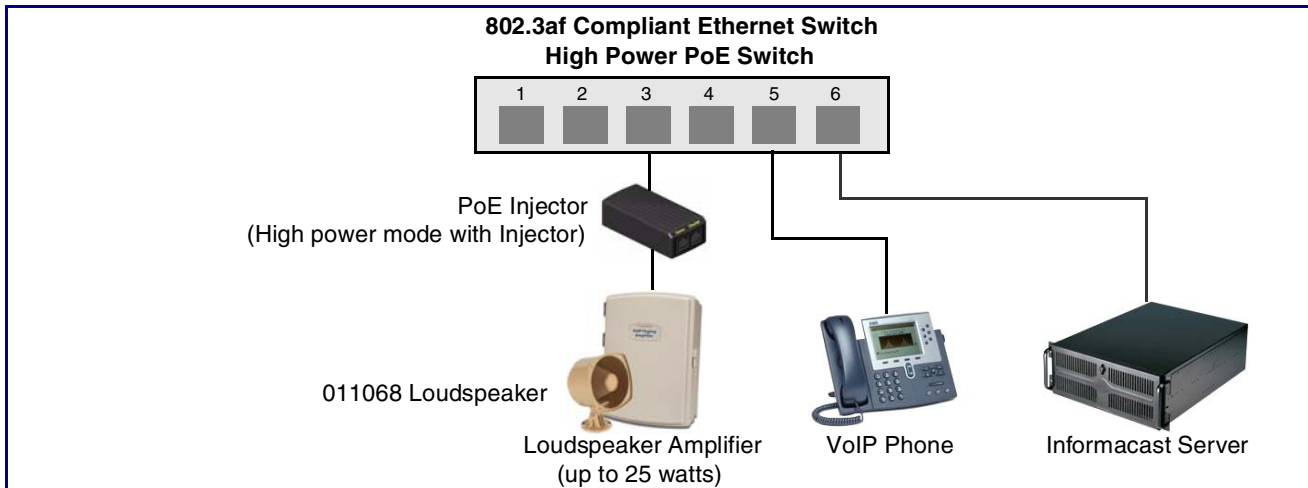

See [Table 2-4](#) for details about the Loudspeaker Amplifier connections.

**Table 2-4. Loudspeaker Amplifier Connections**

Connection	Connection Details	Location
Ethernet	<ul style="list-style-type: none"><li>● Use a RJ 45 cable.</li></ul>	VoIP V2 Loudspeaker Amplifier

### 2.2.5.1 Loudspeaker Type

Using the amplified output, the CyberData VoIP V2 Loudspeaker Amplifier supports the 011068 Loudspeaker or equivalent unamplified loudspeaker.

**Figure 2-10. 011068 Loudspeaker**



### 2.2.5.2 Cabling/Wiring

Using the amplified output, you may connect a loudspeaker to a Loudspeaker Amplifier with a good quality speaker cable that is limited to 25 feet in length.

## 2.2.6 Confirm Operation

After connecting the Loudspeaker Amplifier to the ethernet hub, use the LEDs on the Loudspeaker Amplifier face to confirm that the Loudspeaker Amplifier is operational and linked to the network.

**Table 2-5. Loudspeaker Amplifier LEDs**

LED	Color	Function
Power	Blue/Green	The power LED is illuminated a steady green when the power is on and in low power mode. The power LED is illuminated a steady blue when the amplifier is in high power mode. The power LED will blink during a boot up or a phone call.
Status	Green	After supplying power to the Loudspeaker Amplifier, a steady LED confirms that the Loudspeaker Amplifier is operational. The status LED will blink during a page when it is online.
Link	Green/Yellow	The Link LED is illuminated green for a 10Mb link or yellow/green for a 100Mb link when the network link to the Loudspeaker Amplifier is established.
Activity	Green	The Activity LED blinks to indicate network traffic.

**Figure 2-11. Loudspeaker Amplifier LEDs—Power and Link**

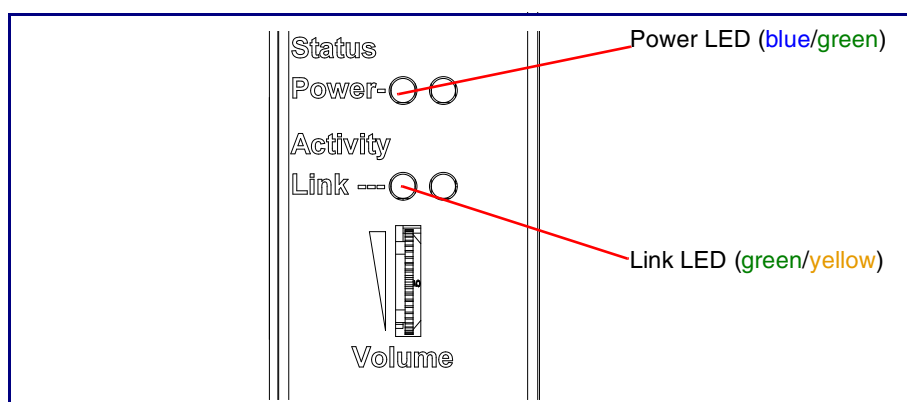

**Figure 2-12. Loudspeaker Amplifier LEDs—Status and Activity**

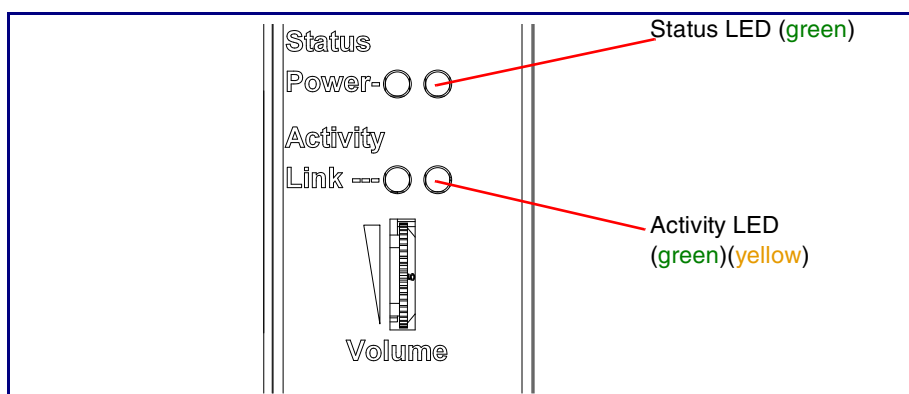

## 2.2.7 Confirm the IP Address and Test the Audio

### 2.2.7.1 RTFM Switch

When the Loudspeaker Amplifier is operational and linked to the network, use the Reset Test Function Management (RTFM) switch (Figure 2-13) on the Loudspeaker Amplifier face to announce and confirm the Loudspeaker Amplifier's IP Address, and test that the audio is working.

**Figure 2-13. RTFM Switch**

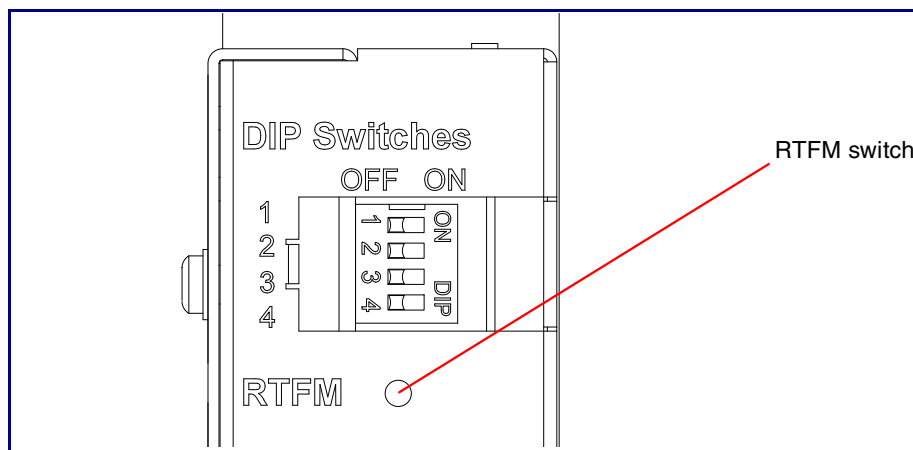

**Announcing the IP Address** To announce a Loudspeaker Amplifier's current IP address:

1. Press and hold the RTFM switch until you hear the IP address announcement.
2. Release the RTFM switch.



#### Caution

*Equipment Caution:* Pressing and holding the RTFM switch for more than five seconds after the IP address announcement will restore the V2 Paging Amplifier to the factory default settings. See the [“Restoring the Factory Default Settings”](#) section.

**Restoring the Factory Default Settings**

To restore the factory default settings, complete the following steps:

1. Press and hold the RTFM switch until you hear the IP address announcement. Continue holding the RTFM switch for an additional five seconds until you hear the Paging Amplifier announce the words, “restoring defaults” and “rebooting”.
2. Release the RTFM switch. The Paging Amplifier will be restored to the factory default settings.

---

## 2.2.8 Adjust the Volume

### 2.2.8.1 External Volume Dial

To adjust the Loudspeaker Amplifier volume, turn the external **Volume** dial (Figure 2-14) on the Loudspeaker Amplifier face.

**Note** For the lineout volume, the volume is fixed and the volume control is adjusted through an external amplifier.

**Figure 2-14. External Volume Dial**

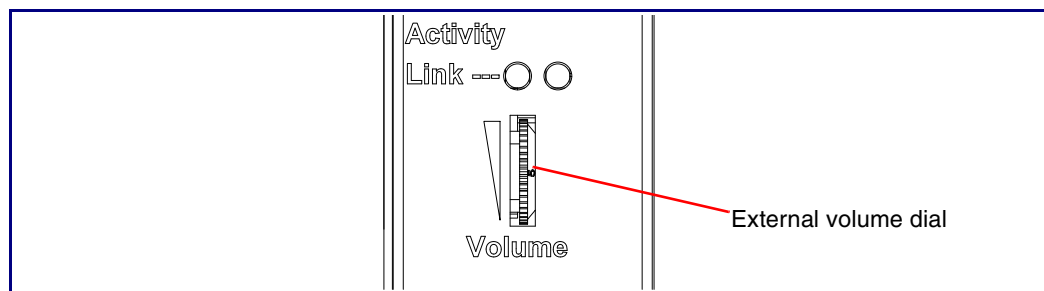

---

## 2.3 Configure the Loudspeaker Amplifier Parameters

To configure the Loudspeaker Amplifier online, use a standard web browser.

Configure each Loudspeaker Amplifier and verify its operation *before* you mount it. When you are ready to mount a Loudspeaker Amplifier enclosure, refer to [Appendix A, "Mounting the Amplifier"](#) for instructions.

All Loudspeaker Amplifier are initially configured with the default IP settings indicated in [Table 2-6](#).

When configuring more than one Loudspeaker Amplifier, attach the Loudspeaker Amplifiers to the network one at a time to avoid IP address conflicts.

**Table 2-6. Factory Default Settings**

Parameter	Factory Default Setting
IP Addressing	DHCP
IP Address <sup>a</sup>	10.10.10.10
Web Access Username	admin
Web Access Password	admin
Subnet Mask <sup>a</sup>	255.0.0.0
Default Gateway <sup>a</sup>	10.0.0.1



a. Default if there is not a DHCP server present.

---

## 2.3.1 Loudspeaker Amplifier Web Page Navigation

Table 2-7 shows the navigation buttons that you will see on every Loudspeaker Amplifier web page.

**Table 2-7. V2 Paging Amplifier Web Page Navigation**

Web Page Item	Description
	Link to the <b>Home</b> page.
	Link to the <b>Update Firmware</b> page.

---

## 2.3.2 Log in to the Configuration Home Page

1. Open your browser to the Loudspeaker Amplifier IP address.

**Note** If the network does not have access to a DHCP server, the device will default to an IP address of 10.10.10.10.

**Note** Make sure that the PC is on the same IP network as the Loudspeaker Amplifier.

**Note** You may also download CyberData's VoIP Discovery Utility program which allows you to easily find and configure the default web address of the CyberData VoIP products.

CyberData's VoIP Discovery Utility program is available on the VoIP V2 Loudspeaker Amplifier product page at:

[http://www.cyberdata.net/support/voip/discovery\\_utility.html](http://www.cyberdata.net/support/voip/discovery_utility.html)

The Loudspeaker Amplifier ships in DHCP mode. To get to the **Home** page, use the discovery utility to scan for the device on the network and open your browser from there.



2. When prompted, use the following default **Web Access Username** and **Web Access Password** to access the **Home Page** (Figure 2-15):

Web Access Username: **admin**

Web Access Password: **admin**

Figure 2-15. Home Page

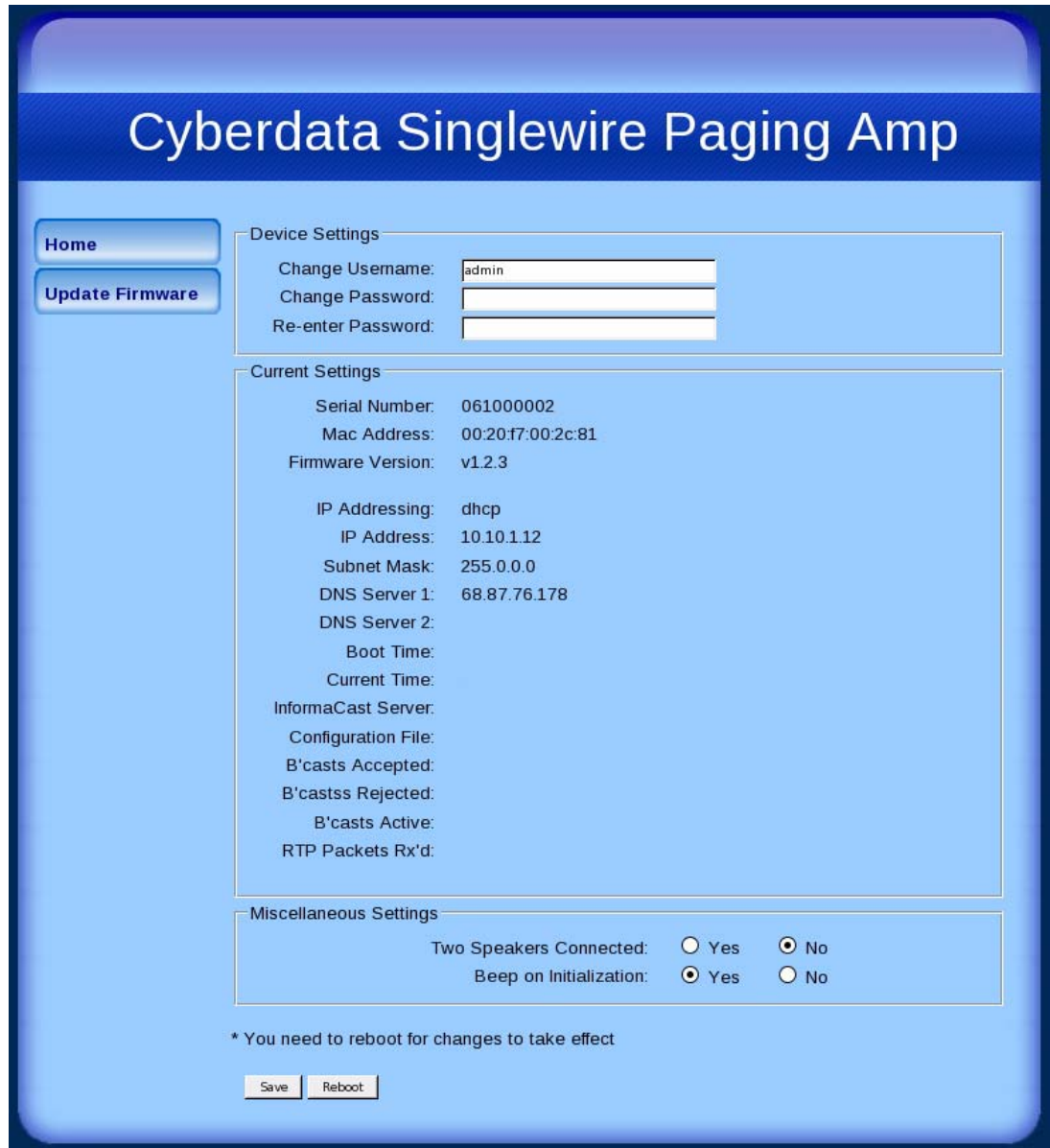

**Note** Figure 2-15 shows the factory default settings.

3. On the **Home Page**, review the setup details and navigation buttons described in [Table 2-8](#).

**Table 2-8. Home Page Overview**

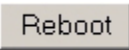
Web Page Item	Description
<b>Device Settings</b>	
Device Name	Shows the device name (25 character limit).
Change Username	Type in this field to change the username (25 character limit).
Change Password	Type in this field to change the password (19 character limit).
Re-enter Password	Type the password again in this field to confirm the new password (19 character limit).
<b>Current Settings</b>	
Serial Number	Shows the device serial number.
Mac Address	Shows the device Mac address.
Firmware Version	Shows the current firmware version.
IP Addressing	Shows the current IP addressing setting ( <b>DHCP</b> or <b>Static</b> ).
IP Address	Shows the current IP address.
Subnet Mask	Shows the current subnet mask address.
Default Gateway	Shows the current default gateway address.
DNS Server 1	Shows the current DNS Server 1 address.
DNS Server 2	Shows the current DNS Server 2 address.
Boot Time	Shows the boot time.
Current Time	Shows the current time.
InformaCast Server	Shows the InformaCast Server IP address.
Configuration File	Shows the configuration file.
B'casts Accepted	Shows the number of B'casts accepted.
B'casts Rejected	Shows the number of B'casts rejected.
B'casts Rejected	Shows the number of active B'casts.
RTP Packets Rx'd	Shows the number of RTP packets Rx'd.
<b>Miscellaneous Settings</b>	
Two Speakers Connected	Select either <b>Yes</b> or <b>No</b> to indicate whether you have two speakers connected.
Beep on Initialization	Select either <b>Yes</b> or <b>No</b> to indicate if you want to hear a beep when the unit is powered up.
	Click the <b>Save</b> button to save your configuration settings. <b>Note:</b> You need to reboot for changes to take effect.
	Click on the <b>Reboot</b> button to reboot the system.

---

## 2.3.3 Upgrade the Firmware and Reboot the Loudspeaker Amplifier

To upload the Loudspeaker Amplifier firmware from your PC:

1. Set up a TFTP server.  
If you do not already have a TFTP server running on your network, see [Appendix B, "Setting up a TFTP Server"](#).
2. Retrieve the latest Loudspeaker Amplifier firmware from the VoIP V2 Loudspeaker Amplifier **Downloads** page at:  
<http://www.cyberdata.net/products/voip/digitalanalog/singlewireloudspeakerampv2/downloads.html>
3. Unzip the Loudspeaker Amplifier version file. This file may contain the following:
  - Firmware file
  - Release notes
4. Copy the firmware files to be upgraded to the appropriate TFTP server directory:
  - c:\tftp-root\for Windows
  - /tftpboot/for Linux
5. Log in to the Loudspeaker Amplifier home page as instructed in [Section 2.3.2, "Log in to the Configuration Home Page"](#).

6. Click the **Update Firmware** button to open the **Upgrade Firmware** page. See [Figure 2-16](#).

**Figure 2-16. Firmware Upgrade Page**

Cyberdata Singlewire Paging Amp

Home Upgrade Firmware

Update Firmware Firmware Version: v1.2.3

TFTP Server IP: 10.0.1.14

New Filename:

System will automatically reboot after upgrading firmware

Submit Reboot

**Note** [Figure 2-16](#) shows the factory default settings.

7. Enter the IP address of your TFTP server into the **TFTP Server IP** parameter field.
8. Enter the firmware filename of the file to be uploaded into the **New Filename** parameter field.  
For example, kernel filename **100-uImage-pagingamp.bin**.
9. Click **Upload File**.

**Note** This starts the upload process. Once the Loudspeaker Amplifier has uploaded the file, the **Uploading Firmware** countdown page appears, indicating that the firmware is being written to flash. The Loudspeaker Amplifier will automatically reboot when the upload is complete. When the countdown finishes, the **Upgrade Firmware** page will refresh. The uploaded firmware filename should be displayed in the system configuration (indicating successful upload and reboot).

Table 2-9 shows the web page items on the **Upgrade Firmware** page.

**Table 2-9. Firmware Upgrade Parameters**

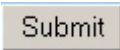
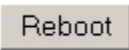
Web Page Item	Description
Firmware Version	Shows the current firmware version.
TFTP Server IP address	Enter the IP address of your TFTP server into the <b>TFTP Server IP</b> parameter field (15 character limit).
New Filename	Use this field to enter the new file name for the firmware file that you are uploading (25 character limit).
	Click on the <b>Submit</b> button to automatically upload the selected firmware and reboot the system.
	Click on the <b>Reboot</b> button to reboot the system.

## 2.3.4 Reboot the Loudspeaker Amplifier

To reboot a Loudspeaker Amplifier, log in to the web page as instructed in [Section 2.3.2, "Log in to the Configuration Home Page"](#).

1. Click **Update Firmware** to open the **Upgrade Firmware** page ([Figure 2-17](#)).

**Figure 2-17. Reboot System Section**

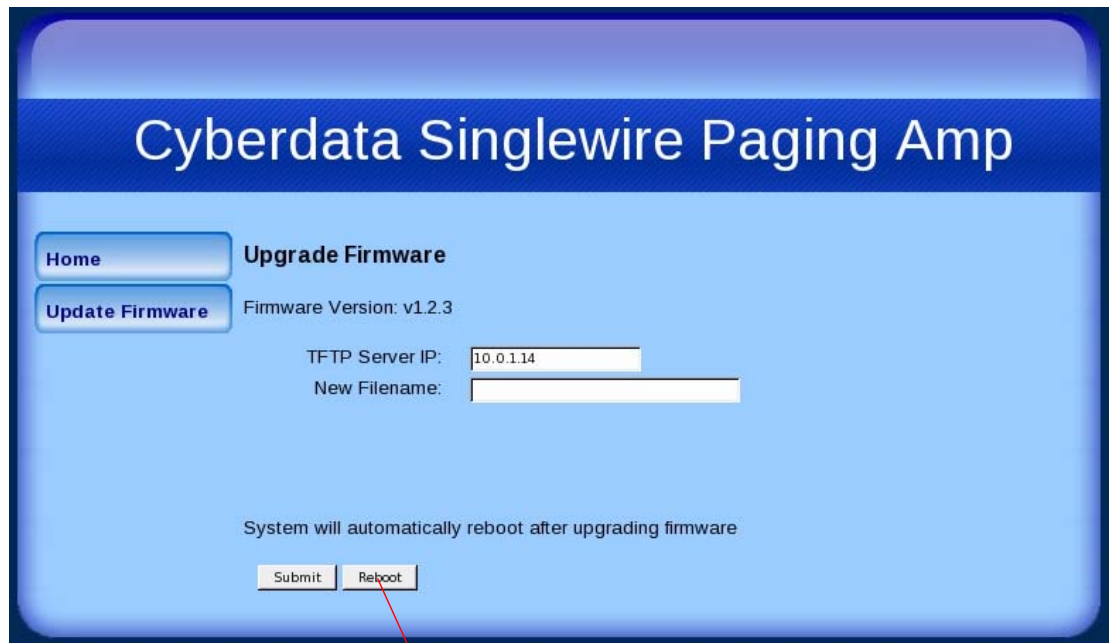

Reboot

2. Click **Reboot**. A normal restart will occur and you will see the following Reboot page.

**Figure 2-18. Reboot Page**



## 2.4 Identifying and Testing a Loudspeaker Amplifier when Using InformaCast 4.0 or Later

This section describes the basic process for identifying and testing the CyberData Loudspeaker Amplifier when using Singlewire's InformaCast software version 4.0 or later.

**Note** If you have questions or need help, please consult your InformaCast documentation and or contact the CyberData support team.

**Note** CyberData's support is limited to IP endpoint functionality when used with an InformaCast system.

To add the Loudspeaker Amplifier to the InformaCast server:

1. Click **Edit IP Speakers** on the **Main Screen** of the **Singlewire Informacast Server Web Interface**.

**Figure 2-19. Main Screen of the Singlewire InformaCast Server Web Interface**

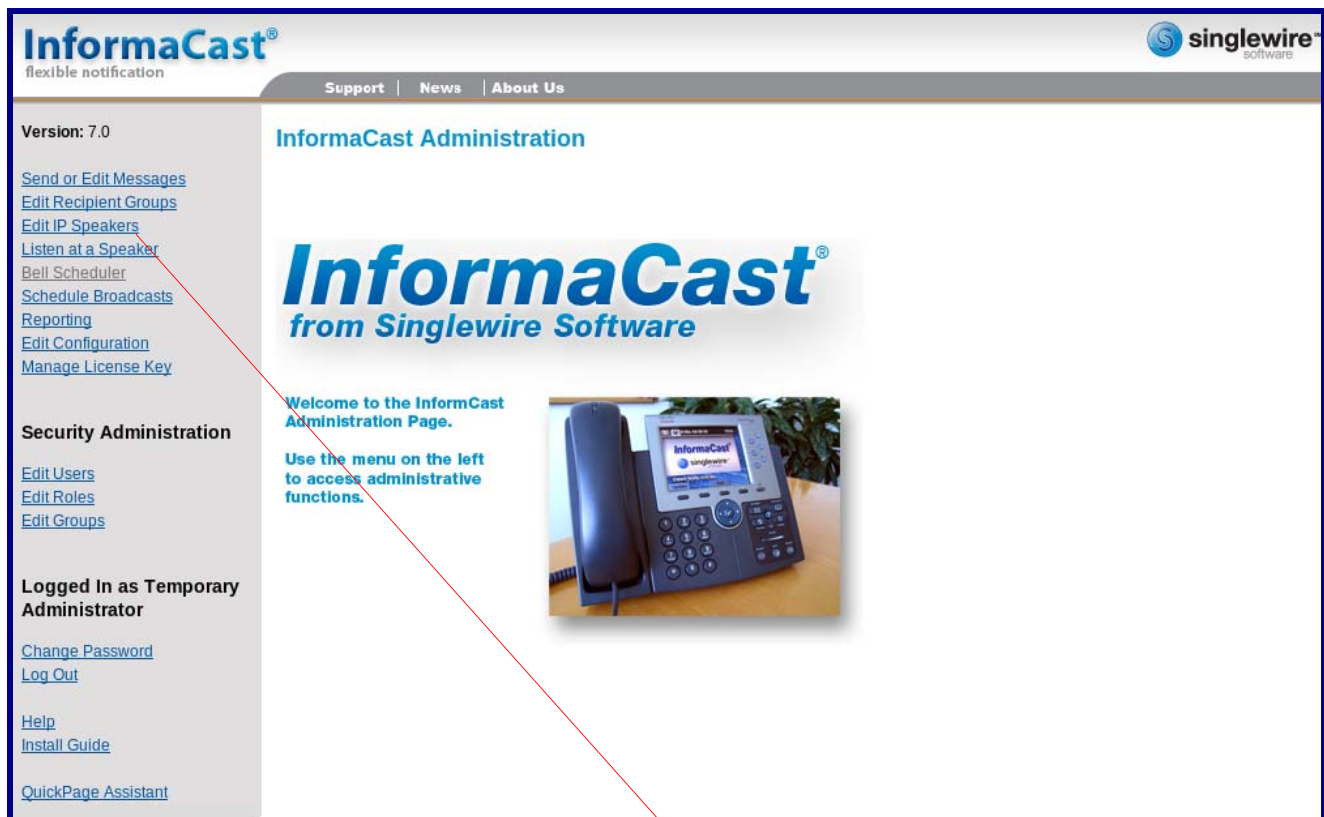

Edit IP Speakers

2. On the **IP Speaker Configuration** page, InformaCast will indicate that it has detected new units. Click **View**.

Figure 2-20. IP Amplifier Configuration Page

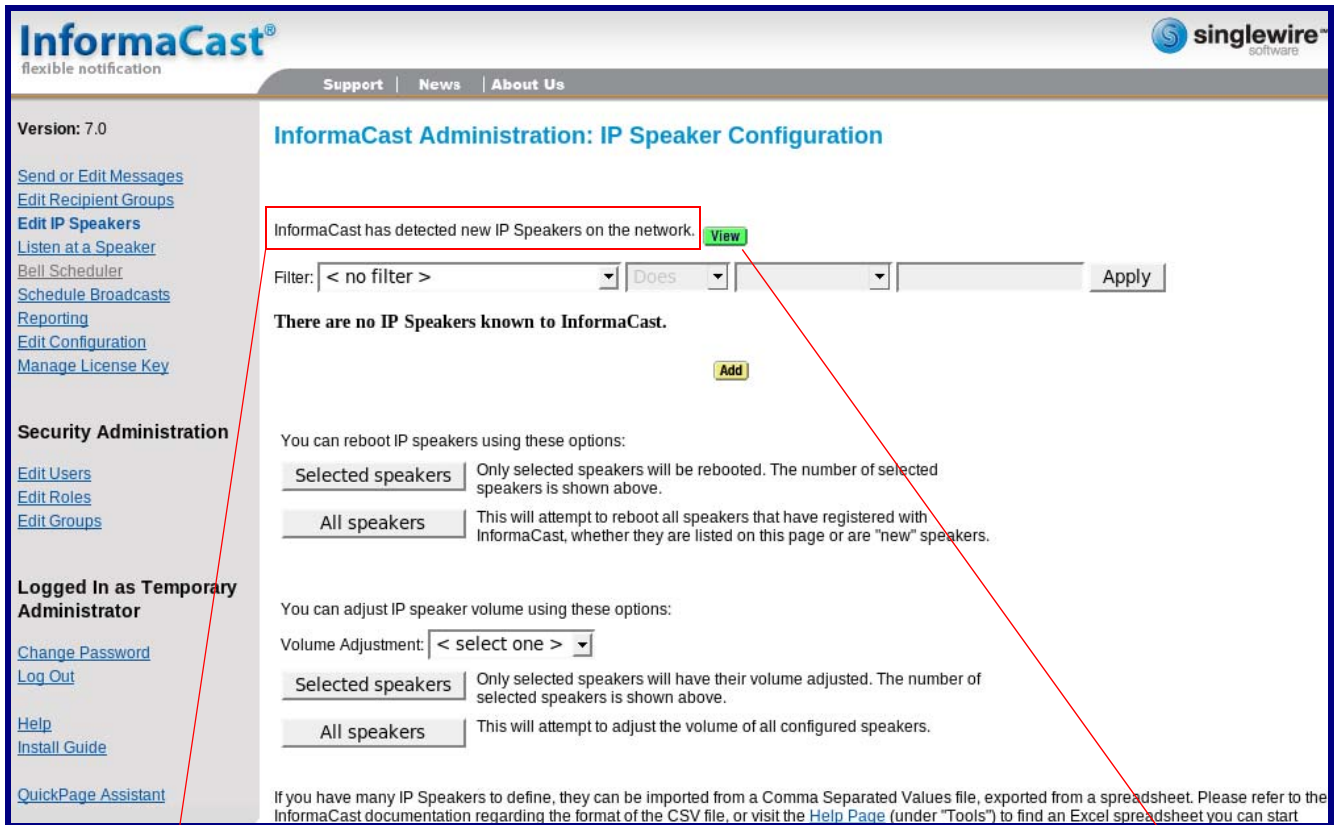

InformaCast has detected new Speakers.

View



3. The **IP Speaker Configuration** page will show four newly detected units. Click **Test**.

Figure 2-21. IP Speaker Configuration Page

The screenshot displays the InformaCast Administration interface for IP Speaker Configuration. The page title is "InformaCast Administration: IP Speaker Configuration". Below the title, there is a count of "0" speakers. A table lists four registered speakers with their MAC addresses, registration details, and action buttons. A red arrow points from the "Test" button in the first row of the table to the word "Test" located below the screenshot.

MAC address	Registration Status	Action
0020f7002dc2	Registered at Thu Dec 17 12:05:55 GMT-07:00 2009 (can record), IP=10.10.1.190	<a href="#">Add</a> <a href="#">Test</a>
0020f7002dc3	Registered at Thu Dec 17 12:05:52 GMT-07:00 2009 (can record), IP=10.10.0.192	<a href="#">Add</a> <a href="#">Test</a>
0020f7002dc4	Registered at Thu Dec 17 12:06:12 GMT-07:00 2009 (can record), IP=10.10.1.191	<a href="#">Add</a> <a href="#">Test</a>
0020f7002dc5	Registered at Thu Dec 17 12:05:59 GMT-07:00 2009 (can record), IP=10.10.0.193	<a href="#">Add</a> <a href="#">Test</a>

[View](#) configured speakers.

Test

4. On the **Test IP Speaker** page, Enter a number into the **Test duration** field.
5. Click **Test**.
6. You will hear a tone from the unit being testing.
7. After the test, click **Cancel** to return to the **IP Configuration** page.

**Figure 2-22. Test IP Speaker Page**

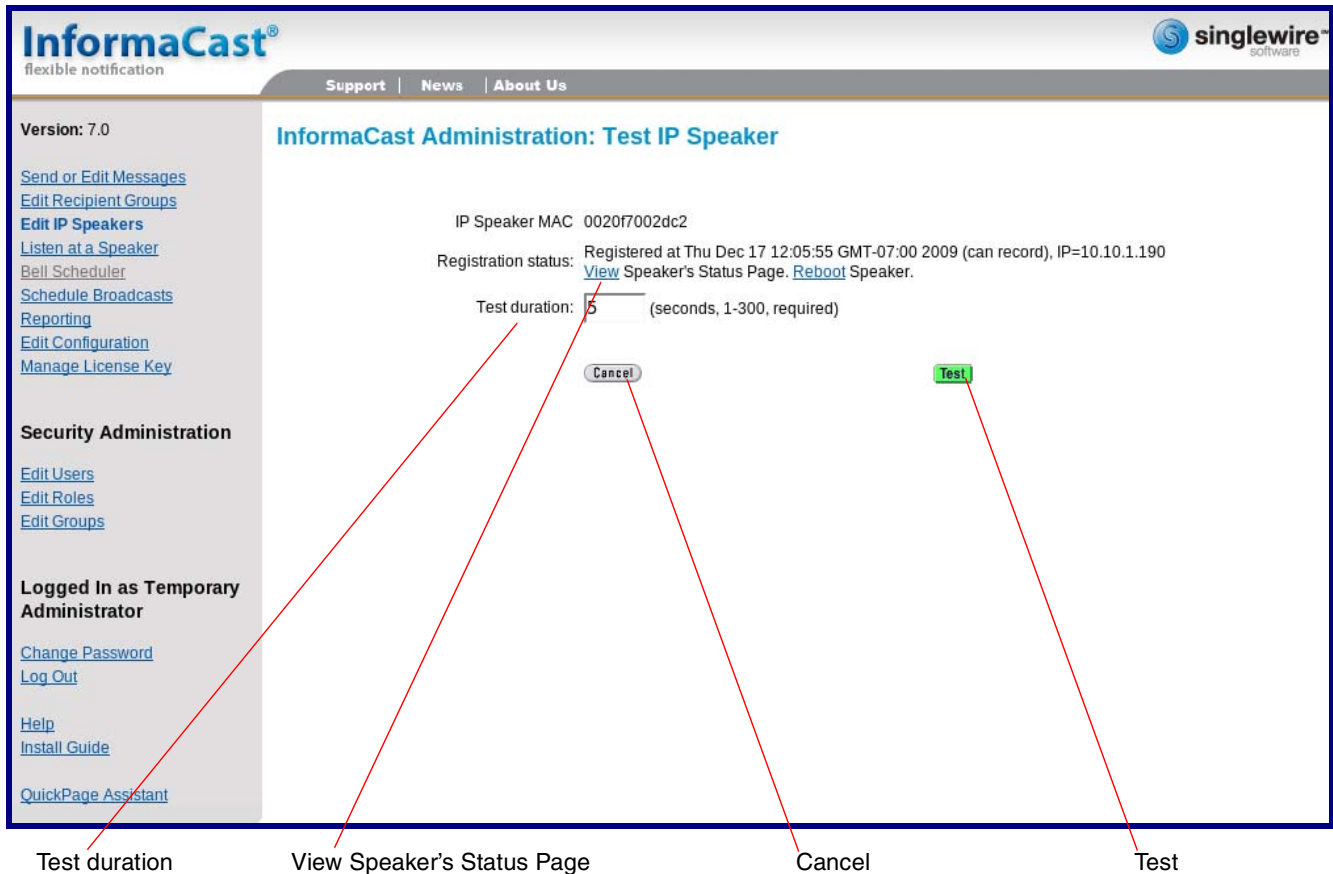

**Note** When viewing the unit's status page via Informacast, Informacast links to the wrong port and path.

Informacast expects our unit's status page to be at:

<http://<ipaddr>:10004/status>.

The status page is actually at:

[http://<ipaddr>/ \(port 80\)](http://<ipaddr>/ (port 80))

Therefore, if a user clicks the link to view the status page and is directed to:

<http://10.10.10.10:1004/status>

The user will need to edit the url in the address bar to:

<http://10.10.10.10/>

8. On the **IP Speaker Configuration** page, Click **Add** to add a Loudspeaker Amplifier to the InformaCast server.

Figure 2-23. IP Configuration Page

The screenshot displays the InformaCast Administration interface for IP Speaker Configuration. The page title is "InformaCast Administration: IP Speaker Configuration". On the left sidebar, there are navigation links for "Send or Edit Messages", "Edit Recipient Groups", "Edit IP Speakers", "Listen at a Speaker", "Bell Scheduler", "Schedule Broadcasts", "Reporting", "Edit Configuration", and "Manage License Key". Below these are sections for "Security Administration" (Edit Users, Edit Roles, Edit Groups) and "Logged In as Temporary Administrator" (Change Password, Log Out, Help, Install Guide, QuickPage Assistant). The main content area shows a table of registered speakers. The table has three columns: "MAC address", "Registration Status", and "Action". There are four rows of data, each with a registered speaker and an "Add" button. A red arrow points from the "Add" button in the table to the "Add" label below the screenshot.

MAC address	Registration Status	Action
0020f7002dc2	Registered at Thu Dec 17 12:05:55 GMT-07:00 2009 (can record), IP=10.10.1.190	<a href="#">Add</a> <a href="#">Test</a>
0020f7002dc3	Registered at Thu Dec 17 12:05:52 GMT-07:00 2009 (can record), IP=10.10.0.192	<a href="#">Add</a> <a href="#">Test</a>
0020f7002dc4	Registered at Thu Dec 17 12:06:12 GMT-07:00 2009 (can record), IP=10.10.1.191	<a href="#">Add</a> <a href="#">Test</a>
0020f7002dc5	Registered at Thu Dec 17 12:05:59 GMT-07:00 2009 (can record), IP=10.10.0.193	<a href="#">Add</a> <a href="#">Test</a>

[View](#) configured speakers.

Add

9. On the **Add IP Speaker** page, Fill out appropriate fields and click **Add**.

**Figure 2-24. Add IP Speaker Page**

The screenshot displays the InformaCast Administration interface for adding a new IP speaker. The page title is "InformaCast Administration: Add IP Speaker". The left sidebar contains navigation links such as "Send or Edit Messages", "Edit Recipient Groups", "Edit IP Speakers", "Listen at a Speaker", "Bell Scheduler", "Schedule Broadcasts", "Reporting", "Edit Configuration", "Manage License Key", "Security Administration", "Logged In as Temporary Administrator", "Change Password", "Log Out", "Help", "Install Guide", and "QuickPage Assistant". The main content area contains the following form fields:

- IP Speaker Name:  (required)
- Speaker Description:
- Dial Code:  (numeric shortcut for optional phone interface)
- MAC Address:  (required, 12 hex digits)
- Volume:

At the bottom of the form are two buttons: "Cancel" and "Add". A red arrow originates from the "Add" button and points to the word "Add" located at the bottom right of the page.



Your unit is now registered to the InformaCast server. You now can configure this device as part of the InformaCast system setup as required.

# Appendix A: Mounting the Amplifier

## A.1 Mount the Loudspeaker Amplifier

Before you mount the enclosure, make sure that you have received all of the parts for each enclosure. Refer to [Table A-10](#).

**Table A-10. Wall Mounting Components (Part of the Accessory Kit)**

Quantity	Part Name	Illustration
3	#6 Plastic Ribbed Anchors	
3	#6 Sheet Metal Screws	

**Note** The Loudspeaker Amplifier was designed for indoor use. Mounting it on the external part of a building will require additional hardware for weatherproofing, cabling access, and lightning suppression. Consult a certified electrician for details.

**Note** For mounting, use the three #6 **SHEET METAL SCREWS** to secure the enclosure.

## A.1.1 Mounting the Enclosure

To mount the enclosure:

1. Prepare holes for the screws.
2. Plug in the power adapter and use the green Power light to verify that the power is on.
3. Plug the Ethernet cable into the Loudspeaker Amplifier. The yellow Link light verifies the network connection.
4. For wall mounting, use the three #6 x 1-1/4-inch Pan Head Phillip screws to secure the speaker. See [Figure A-1.](#)

**Figure A-1. Mounting the Enclosure**

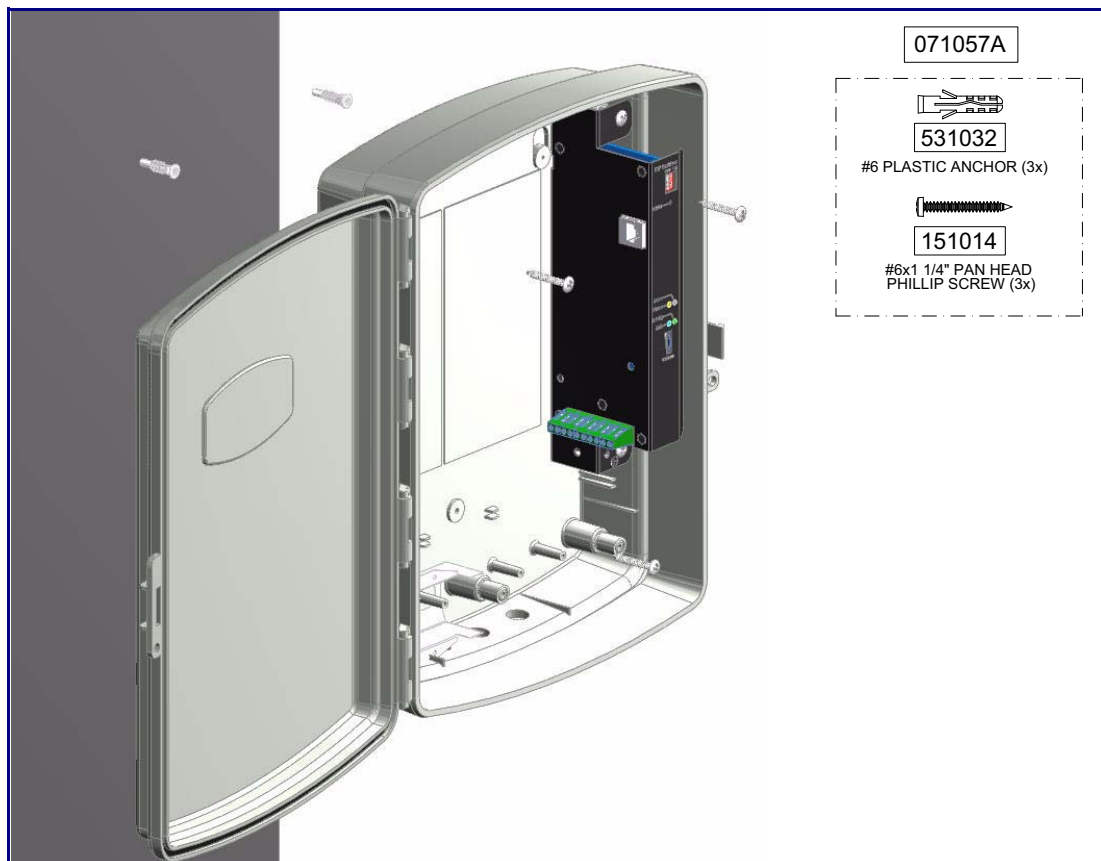

# Appendix B: Setting up a TFTP Server

---

## B.1 Set up a TFTP Server

Upgrading the VoIP V2 Loudspeaker Amplifier firmware requires a TFTP server on which you access the Web interface where you can upload the firmware files.

---

### B.1.1 In a LINUX Environment

To set up a TFTP server on LINUX:

1. Create a directory dedicated to the TFTP server, and move the files to be uploaded to that directory.
2. Run the following command where `/tftpboot/` is the path to the directory you created in [Step 1](#): the directory that contains the files to be uploaded. For example:

```
in.tftpd -l -s /tftpboot/your_directory_name
```

---

### B.1.2 In a Windows Environment

You can find several options online for setting up a Windows TFTP server. This example explains how to use the Solarwinds freeware TFTP server, which you can download at:

<http://www.cyberdata.net/support/voip/solarwinds.html>

To set up a TFTP server on Windows:

1. Install and start the software.
2. Select **File/Configure/Security** tab/**Transmit Only**.
3. Make a note of the default directory name, and then move the firmware files to be uploaded to that directory.

# Appendix C: Troubleshooting/Technical Support

---

## C.1 Frequently Asked Questions (FAQ)

To see a list of frequently asked questions for your product, do the following:

1. Go to the following URL:

<http://www.cyberdata.net/products/voip/digitalanalog/singlewireloudspeakerampv2/faqs.html>

2. Go to the support page for your product, and click on the **FAQs** tab.

---

## C.2 Documentation

The documentation for this product is released in an English language version only. You can download PDF copies of CyberData product documentation by doing the following:

1. Go to the following URL:

<http://www.cyberdata.net/products/voip/digitalanalog/singlewireloudspeakerampv2/docs.html>

2. Go to the support page for your product, and click on the **Documentation** tab.



## C.3 Contact Information

Contact	<p>CyberData Corporation                  2555 Garden Road                  Monterey, CA 93940                  USA  <a href="http://www.CyberData.net">www.CyberData.net</a>                  Phone: 800-CYBERDATA (800-292-3732)                  Fax: 831-373-4193</p>
Sales	<p>Sales 831-373-2601 Extension 334</p>
Technical Support	<p>Phone: 831-373-2601 Extension 333                  Web: <a href="http://www.cyberdata.net/support/contactsupportvoip.html">http://www.cyberdata.net/support/contactsupportvoip.html</a></p>
Returned Materials Authorization	<p>To return the product, contact the CyberData Returned Materials Authorization (RMA) department at:</p> <p>Phone: 831-373-2601, Extension 136                  Email: <a href="mailto:RMA@CyberData.net">RMA@CyberData.net</a></p> <p>When returning a product to CyberData, an approved CyberData RMA number must be printed on the outside of the original shipping package. No product will be accepted for return without an approved RMA number. Send the product, in its original package, to the following address:</p> <p>CyberData Corporation                  2555 Garden Road                  Monterey, CA 93940                  Attention: RMA "your RMA number"</p>
RMA Status Form	<p>If you need to inquire about the repair status of your product(s), please use the CyberData RMA Status form at the following web address:</p> <p><a href="http://www.cyberdata.net/support/rmastatus.html">http://www.cyberdata.net/support/rmastatus.html</a></p>

## C.4 Warranty

CyberData warrants its product against defects in material or workmanship for a period of two years from the date of purchase. Should the product fail within the warranty period, CyberData will repair or replace the product free of charge. This warranty includes all parts and labor.

Should the product fail out-of-warranty, a flat rate repair charge of one half of the purchase price of the product will be assessed. Repairs that are in warranty but are damaged by improper modifications or abuse, will be charged at the out-of-warranty rate. Products shipped to CyberData, both in and out-of-warranty, are shipped at the expense of the customer. Shipping charges for repaired products shipped back to the customer by CyberData, will be paid by CyberData.

CyberData shall not under any circumstances be liable to any person for any special, incidental, indirect or consequential damages, including without limitation, damages resulting from use or malfunction of the products, loss of profits or revenues or costs of replacement goods, even if CyberData is informed in advance of the possibility of such damages.

---

## C.4.1 Warranty & RMA Returns within the United States

If service is required, you must contact CyberData Technical Support prior to returning any products to CyberData. Our Technical Support staff will determine if your product should be returned to us for further inspection. If Technical Support determines that your product needs to be returned to CyberData, an RMA number will be issued to you at this point.

Your issued RMA number must be printed on the outside of the shipping box. No product will be accepted for return without an approved RMA number. The product in its original package should be sent to the following address:

CyberData Corporation

2555 Garden Rd.

Monterey, CA 93940

Attn: RMA "xxxxxx"

---

## C.4.2 Warranty & RMA Returns Outside of the United States

If you purchased your equipment through an authorized international distributor or reseller, please contact them directly for product repairs.

---

## C.4.3 Spare in the Air Policy

CyberData now offers a *Spare in the Air* no wait policy for warranty returns within the United States and Canada. More information about the *Spare in the Air* policy is available at the following web address:

<http://www.cyberdata.net/support/warranty/spareintheair.html>

---

## C.4.4 Return and Restocking Policy

For our authorized distributors and resellers, please refer to your CyberData Service Agreement for information on our return guidelines and procedures.

For End Users, please contact the company that you purchased your equipment from for their return policy.

---

## C.4.5 Warranty and RMA Returns Page

The most recent warranty and RMA information is available at the CyberData Warranty and RMA Returns Page at the following web address:

<http://www.cyberdata.net/support/warranty/index.html>

# Index

---

## Symbols

#6 sheet metal screws 30

## A

accessory kit 5  
 activity LED 13  
 address, configuration login 17  
 announcing an IP address 14  
 audio encodings 3

## C

components 8  
 configurable parameters 19  
 configuration  
   default IP settings 16  
   using Web interface 16  
 configuration home page 18  
 configuration page  
   configurable parameters 19  
 connections 8  
 connections (power) 9  
 connections inside of the NEMA box 8  
 contact information 34  
 contact information for CyberData 34  
 CyberData contact information 34  
 CyberData support limited to IP endpoint  
   functionality 24

## D

default  
   gateway 6, 16  
   IP address 6, 16  
   subnet mask 6, 16  
   username and password 6, 16  
   web login username and password 18  
 default gateway 6, 16  
 default IP settings 16  
 default login address 17  
 DHCP Client 3  
 discovery utility program 17

## E

enclosure, mounting 30

## F

factory defaults 7, 14  
 firmware  
   where to get the latest firmware 20  
 firmware upgrade parameters 22  
 firmware upgrades 32

## H

hazard levels 5  
 home page 18  
 http web-based configuration 3

## I

identifying the speaker (when using InformaCast 4.0) 24  
 identifying your product 1  
 illustration of amplifier mounting process 30  
 InformaCast  
   Add IP Speaker Page 29  
   IP Speaker Configuration page 25  
   Test IP Speaker Page 27  
   testing and identifying a Singlewire-enabled ceiling  
   speaker 24  
 Informacast linking to the wrong port and path 27  
 InformaCast needs to be 4.0 or higher 1  
 installation 2  
 IP address 6, 16, 22  
 IP addressing  
   default  
     IP addressing setting 6, 16

## L

LEDs 13  
 link LED 13  
 Linux, setting up a TFTP server on 32  
 log in address 17  
 loudspeaker, cabling/wiring 12

loudspeaker, type 12

## M

mounting an amplifier 30

## N

navigation (web page) 17

navigation table 17

NEMA box components 8

network link activity, verifying 13

## P

packet time 3

parts list 5

password

login 18

restoring the default 6, 16

power LED 13

power, connecting to loudspeaker amplifier 9

product

configuring 16

mounting 30

parts list 5

product features 3

product overview

product features 3

product specifications 4

supported protocols 3

typical system installation 2

product specifications 4

protocols supported 3

## R

reboot 22, 23

reset test function management switch 14

resetting the IP address to the default 30

restoring the factory defaults 7, 14

return and restocking policy 35

RMA returned materials authorization 34

RMA status 34

RTFM switch 7, 14

RTP/AVP 3

## S

safety instructions 4

sales 34

service 34

setting up a TFTP server 32

Singlewire Informacast Server Web Interface 24

Spare in the Air Policy 35

status LED 13

subnet mask 6, 16

supported protocols 3

## T

tech support 34

technical support, contact information 34

testing the speaker (when using InformaCast 4.0) 24

TFTP server 3, 32

## U

username

default for web configuration access 18

restoring the default 6, 16

## V

verifying

network link and activity 13

power on 13

volume 15

volume dial 15

## W

warranty 34

warranty & RMA returns outside of the United States 35

warranty & RMA returns within the United States 35

warranty and RMA returns page 35

warranty policy at CyberData 34

web access password 6, 16

web access username 6, 16

web configuration log in address 17

web page

navigation 17

web page navigation 17

web-based paging amplifier configuration 16

Windows, setting up a TFTP server on 32