



Grandstream Networks, Inc.

GXV3672_HD/GXV3672_FHD

Outdoor Day/Night IP Camera



TABLE OF CONTENTS
GXV3672_HD/FHD User Manual

WELCOME.....	4
SAFETY COMPLIANCES	5
WARRANTY	6
CONNECT YOUR GXV3672_HD/FHD.....	7
EQUIPMENT PACKAGE CONTENTS.....	7
CONNECTING THE GXV3672_HD/FHD	8
PRODUCT OVERVIEW	9
GXV3672_HD/FHD CAMERA.....	9
GXV3672_HD/FHD SPECIFICATIONS.....	10
INSTALLATION GUIDE	11
MINIMUM RECOMMENDED COMPUTER SYSTEM REQUIREMENT.....	11
CONFIGURE THE GXV3672_HD/FHD VIA WEB BROWSER	11
CONNECT THE CAMERA TO NETWORK WITH DHCP SERVER (RECOMMENDED).....	12
CONNECT TO THE CAMERA USING STATIC IP	13
GXV3672_HD/FHD HOME WEB PAGE	14
GXV3672_HD/FHD CONFIGURATION & LANGUAGE PAGE	14
BASIC SETTINGS EXPLANATION	16
SYSTEM SETTINGS PAGE	16
VIDEO & AUDIO SETTING PAGE	17
CMOS SETTINGS PAGE.....	19
NETWORKING SETTING PAGE	20
DDNS SETTINGS PAGE	21
SIP SETTING PAGE.....	22
STATUS PAGE.....	24
ADVANCED SETTINGS EXPLANATION.....	25
USER MANAGEMENT PAGE.....	25
MAINTENANCE PAGE.....	26
SMTP SETTING PAGE (EMAIL ALARM).....	27
FTP SETTINGS PAGE (UPLOAD ALARM).....	28
ALARM SERVER SETTINGS PAGE (UPLOAD ALARM TO SUPPORTED VMS OR HTTP SERVER)	29
PERIODIC SNAPSHOT	30
MOTION DETECTION CONFIGURATION PAGE (SET ALARM)	31
SYSLOG SETTINGS PAGE (TROUBLESHOOTING)	33
SOFTWARE UPGRADE	34
INSTRUCTIONS FOR LOCAL FIRMWARE UPGRADE USING TFTP SERVER:	35
CONFIGURATION FILE DOWNLOAD	35
RESTORE FACTORY DEFAULT SETTING.....	36
RESET FROM WEB INTERFACE.....	36
IP SURVEILLANCE FAQ	37

TABLE OF FIGURES
GXV3672_HD/FHD USER MANUAL

FIGURE 1: HOME PAGE OF GXV3672_HD/FHD	14
FIGURE 2: WEB LANGUAGE SWITCH	15
FIGURE 3: SYSTEM SETTINGS PAGE.....	16
FIGURE 4-1: VIDEO & AUDIO SETTINGS PAGE.....	17
FIGURE 4-2: VIDEO & AUDIO SETTINGS PAGE.....	18
FIGURE 5: CMOS SETTINGS PAGE.....	19
FIGURE 6: NETWORKING SETTING PAGE.....	20
FIGURE 7: DDNS SETTING PAGE.....	21
FIGURE 8-1: SIP SETTING PAGE.....	22
FIGURE 8-2: SIP SETTING PAGE.....	23
FIGURE 9: STATUS PAGE.....	24
FIGURE 10: USER MANAGEMENT PAGE	25
FIGURE 11: MAINTENANCE PAGE	26
FIGURE 12: SMTP SETTING PAGE	27
FIGURE 13: FTP SETTING PAGE.....	28
FIGURE 14: ALARM HTTP SERVER SETTING PAGE	29
FIGURE 15: PERIOD SNAPSHOTS PAGE.....	30
FIGURE 16-1: MOTION DETECTION CONFIGURATION PAGE.....	31
FIGURE 16-2: MOTION DETECTION SCHEDULE CONFIGURATION PAGE	32
FIGURE 17: ALARM SERVER SETTING PAGE	33
FIGURE 18: FIRMWARE UPGRADE AND PROVISIONING	34
FIGURE 19: FACTORY RESET FROM WEB INTERFACE	36

TABLE OF TABLES
GXV3672_HD/FHD USER MANUAL

TABLE 1: GXV3672_HD/FHD TECHNICAL SPECIFICATIONS.....	ERROR! BOOKMARK NOT DEFINED.
---	-------------------------------------

WELCOME

Thank you for purchasing Grandstream's GXV3672_HD/FHD Outdoor Day/Night High Definition IP Camera, an innovative powerful weatherproof infrared next generation network camera. Its advanced ISP (Image Sensor Processor) powered with state-of-the-art auto-exposure/auto-white-balance algorithm and a high quality lens, ensures high fidelity video quality that matches digital still camera color grade in a wide range of light environments. It features cutting edge H.264 real-time video compression with excellent image clarity (720p for GXV3672HD; 1080p for GXV3672_FHD) and color fidelity, industry leading SIP/VoIP for video streaming to smartphones and video phones, integrated PoE, IR-CUT (mechanical) for day or night mod, and advanced security protection using strong encryption. The GXV3672_HD/FHD can be managed with GSurf_Pro, Grandstream's intuitive FREE VMS (video management systems) software that controls up to 36 cameras (*) simultaneously. It is fully compliant with ONVIF standard and offers flexible HTTP API and an SDK for advanced integration.

The GXV3672_HD/FHD Outdoor Day/Night IP camera is a new addition to the popular GXV3XXX series IP surveillance product family. It ensures ease of use, integration and deployment, with multilingual graphical user interface, provides powerful solution to professional surveillance applications in outdoor environment.

This manual will help you to learn how to operate and manage your GXV3672_HD/FHD Outdoor Day/Night HD IP camera and make the best use of it.

SAFETY COMPLIANCES

These instructions are intended to assist users with the operation of the GXV3672_HD/FHD and to instruct on how to avoid dangerous situations or damage to the device.

Warnings: Serious injury or death may be caused if any of the warnings below are neglected.
Cautions: Injury or damage to the equipment may occur if any of the following caution messages are neglected.



Warning: Follow these safeguards to prevent serious injury or death.



Caution: Follow these precautions to prevent potential injury or material damage.



Warning:

Input voltage should meet both the SELV (Safety Extra Low Voltage) and the Limited Power Source with DC 12V according to the IEC60950-1 standard. Please refer to the technical specifications for more details. Do not use a third-party power adapter or power cord. When the device installed on the wall or ceiling, make sure that it is firmly attached.



Notice:

- Make sure that the power supply voltage is correct before using the camera.
- Do not drop the device or expose it to physical shock.
- Do not expose the device to temperatures outside the range of -20 °C to +45 °C when the device is in operation.
- Do not expose the device to damp/wet conditions or high electromagnetism radiation.
- To avoid heat accumulation, make sure that your operating environment has proper ventilation.
- Do not attempt to open, disassemble, or modify the device

A few parts (e.g. electrolytic capacitor) of the equipment shall be replaced regularly according to their average lifetime. The average lifetime varies from the differences between operating environments and usage history. Regular maintenance checks are recommended for all users. Please contact your dealer for more details.

WARRANTY

If you purchased your GXV3672_HD/FHD from a reseller, please contact the company where you purchased the device for replacement, repair or refund.

If the device was purchased directly from Grandstream, please contact our technical support team for a RMA (Return Materials Authorization) number before the product is returned.

Grandstream reserves the right to remedy warranty policy without prior notification.

Caution:

Changes or modifications to this product not expressly approved by Grandstream, or operation of this product in any way other than as detailed by this User Manual, could void your manufacturer warranty. Please do not use a different power adaptor with the GXV3672_HD/FHD as it may cause damage to the products and void the manufacturer warranty.

- This document is subject to change without notice. The latest electronic version of this user manual is available for download at:
http://www.grandstream.com/products/surveillance/GXV3672hd/documents/gxv3672hd_fhd_usermanual_english.pdf

Reproduction or transmittal of the entire or any part, in any form or by any means, electronic or print, for any purpose is not permitted without the express written permission of Grandstream Networks, Inc.

CONNECT YOUR GXV3672_HD/FHD

Equipment Package Contents

The GXV3672_HD/FHD package contains:

- GXV3672_HD/FHD IP Camera
- 12V DC Universal Power Adaptor
- Ethernet Cable
- Hex Key and 3 Screws and Wall Anchors
- Quick Installation Guide



1 x GXV3672_HD/FHD



1 x 12V Power Supply



1 x Ethernet Cable



3 x Wall Anchors



3 x Screw



1 x Hex Key



1 x Quick Start Guide

Connecting the GXV3672_HD/FHD

Using the Power Adapter as power supply

- Connect the RJ-45 Ethernet cable to the NETWORK port of the GXV3672_HD/FHD
- Connect the other end of the RJ-45 cable to your network (switch or router or PC)
- Connect the power supply to the DC 12V power jack on the back of the GXV3672_HD/FHD

Using PoE as power supply

- Connect the RJ-45 Ethernet cable to the NETWORK port of GXV3672_HD/FHD
- Connect the other end of the RJ-45 cable to your PoE switch.

Please refer to following connection diagram to hook up the camera.

Refer to the illustration below when following the instructions on the next page.

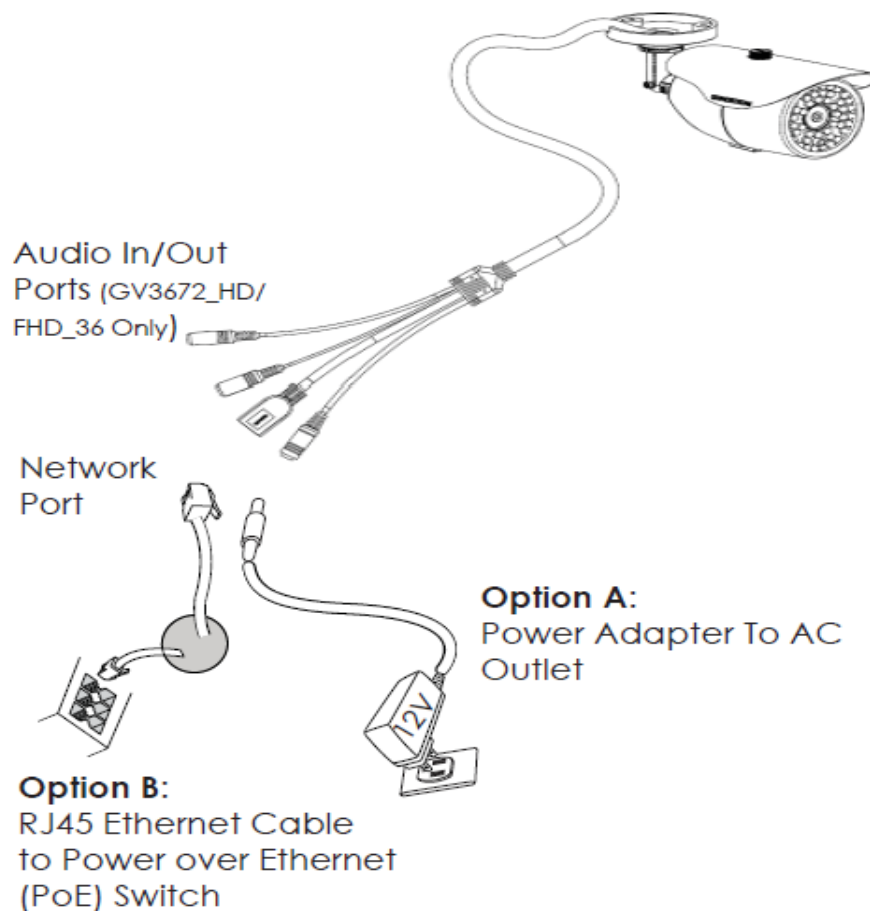

NOTE: Choose Option A if using the power supply; or choose Option B if using a Power over Ethernet (PoE) switch.

PRODUCT OVERVIEW

GXV3672_HD/FHD Camera

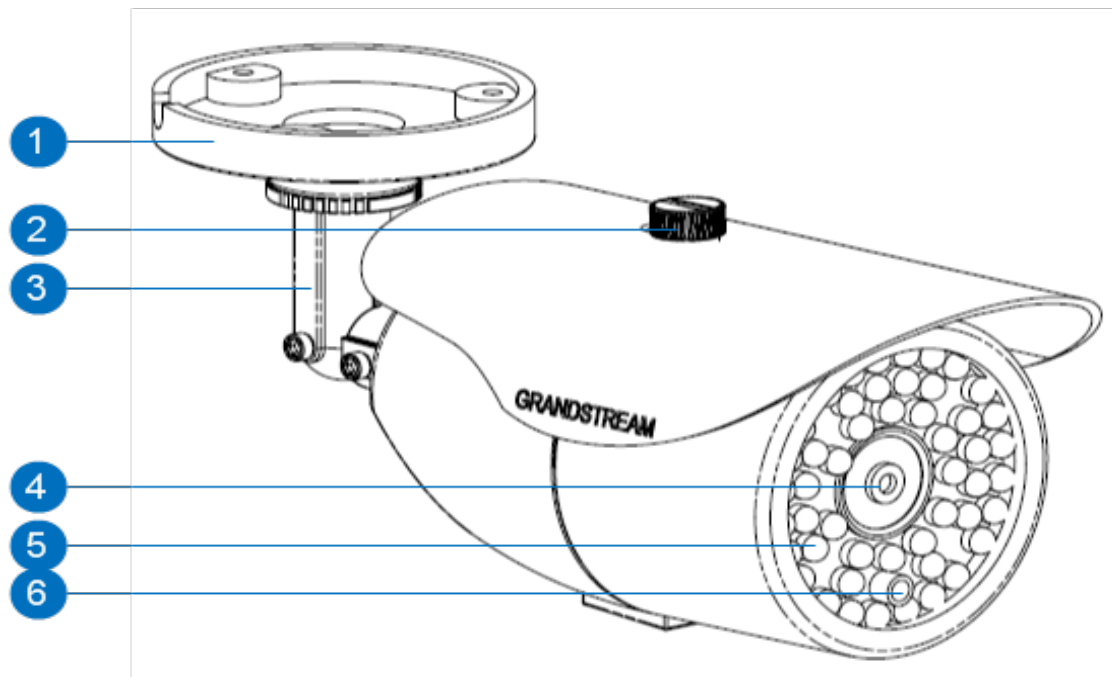

- | | |
|-----------------------------------|---|
| 1. Mounting Plate | GXV3672_HD/FHD Mounting Plate |
| 2. Top Shield Cover/Screw | Top metal cover (shielding direct light and rain, etc.) |
| 3. Adjustable Wire Shield | Adjustable cylinder for wiring shield |
| 4. Lens | 1/3" CMOS (1.2M for HD/3.1M for FHD) and Lens |
| 5. IR Light Array | Infrared Light Array |
| 6. Light Sensor for IR-Cut | Light Sensor for mechanical IR-Cut switching |

GXV3672_HD/FHD Specifications

Model	GXV3672_HD_36 GXV3672_HD	GXV3672_FHD_36 GXV3672_FHD
Video Compression	H.264, MJPEG	
Image Sensor Resolution	1/3", 1.2 Megapixel Progressive Scan CMOS, 1280H x 960V	1/3", 3.1 Megapixel Progressive Scan CMOS, 2048H x 1536V
Image Sensor Sensitivity	Day/Night Mode (exceptional low noise level, low light sensitivity) Shutter: 1/10000 – 1/30 second	
Focal Length	3.6mm: GXV3672_HD_36 & GXV3672_FHD_36 8.0mm: GXV3672_HD & GXV3672_FHD	
Aperture	F1.8	
Field Angle (FOV)	3.6mm: 100.2°(D) x 77°(H) x 54°(V) 8.0mm: 46°(D) x 36°(H) x 26.5°(V)	
IR Cut Filter	Yes, Mechanical	
Day & Night Mode	3.6mm: IR LED covering up to 10 meter 8.0mm: IR LED covering up to 30 meter	
Minimum Illumination	0.05 Lux; 0 Lux with IR LED On	
Responsivity	5.48V/Lux-sec (550nm)	1.9V/Lux-sec (550nm)
Supported Maximum Video Resolution and Frame Rate	1280x960 (25fps) 1280x720 (30fps)	2048x1536 (15fps) 1920x1080 (30fps)
Video Bit Rate	32 Kbps ~ 8 Mbps, Multi-rate for Preview & Recording	
Audio Input	Line-In, 1500 ohms, 0.1Vrms ~ 0.707Vrms (GXV3672_HD/FHD_36 only)	
Audio Output	Line-Out, 600 ohms, 0.707Vrms (GXV3672_HD/FHD_36 only)	
Audio Compression	G.711u/a, AAC	
Embedded Analytics	Motion Detection (up to 16 target areas)	
Pre-/post-alarm Buffer	8MB	3MB
Snapshots	Triggered upon events, Send via email/FTP	
Network Protocol	TCP/UDP/IP, RTP/RTCP, RTSP, DHCP, DDNS, HTTP, HTTPS, SMTP, FTP, NTP	
SIP/VoIP Support	Yes	
Power over Ethernet (PoE)	IEEE 802.3af, Class 0	
External Cable Connection	Network: RJ45, 10M/100M Auto-Sensing 3.5mm Line-In (GXV3672_HD/FHD_36 only) 3.5mm Line-Out (GXV3672_HD/FHD_36 only) Power Input	
Dimensions (D x L)	94mm (D) x 230mm (L)	
Weight	0.52kg	
Temperature / Humidity	Operating: -20°C ~ 45°C (-4°F ~ 113°F) 10 ~ 90%, RH(non-condensing) Storage: -30°C ~ 60°C (-22°F ~ 140°F)	
Power Adapter	Output: 12VDC/1A; Input: 100–240VAC, 50–60Hz	
Casing	IP66 Compliant Weather-Proof Metal Case	
Compliance	FCC Part 15, Subpart B Class B; EN 55022 Class B, EN 61000-3-2, EN 61000-3-3, EN 55024, EN 60950-1; C-tick AS/NZS CISPR 22	

Table 1: GXV3672_HD/FHD Technical Specifications

INSTALLATION GUIDE

Minimum Recommended Computer System Requirement

To install GXV3672_HD/FHD, you have to have a computer, PC recommend. The minimum recommended PC system requirement listed below:

- Windows 2000, XP, Windows Vista, Windows 7 (32bit or 64bit)
- CPU: Intel Pentium 4 or higher, 2 GHz
- RAM: 1 GB (4 GB recommended for larger systems)
- Support for DirectX 8.0 and above.

Configure the GXV3672_HD/FHD via Web Browser

The GXV3672_HD/FHD has embedded Web server to respond to HTTP GET/POST requests. Embedded HTML pages allow user to configure the IP camera through Microsoft Internet Explorer (7.0 or above), Firefox or Chrome (plug-in from Grandstream required).

- Download WebControl Plug-in from Grandstream website:
http://www.grandstream.com/products/tools/surveillance/webcontrl_plugin.zip

NOTE:

- *Apple Safari is NOT yet supported and status pending.*
- *Please temporarily disable Antivirus or Internet Security Software when download and install the Grandstream Webcontrol Plug-in for Firefox/Chrome or “GSViewerX.cab” for Microsoft Internet Explorer.*

Connect the Camera to network with DHCP server (Recommended)

The GXV3672_HD/FHD by default enabled as DHCP client, it will automatically get IP address from the network with DHCP server running. User can know the IP address assigned to the camera from DHCP server log or using Grandstream free GS_Search tool.

1. Download the GS_Search tool from Grandstream website:
http://www.grandstream.com/products/tools/surveillance/GS_Search.zip
2. Run the Grandstream GS_Search tool by double click the unzipped “GS_Search.exe”.
3. Click on the  button to begin device detection
4. The detected devices will appear in the output field like below

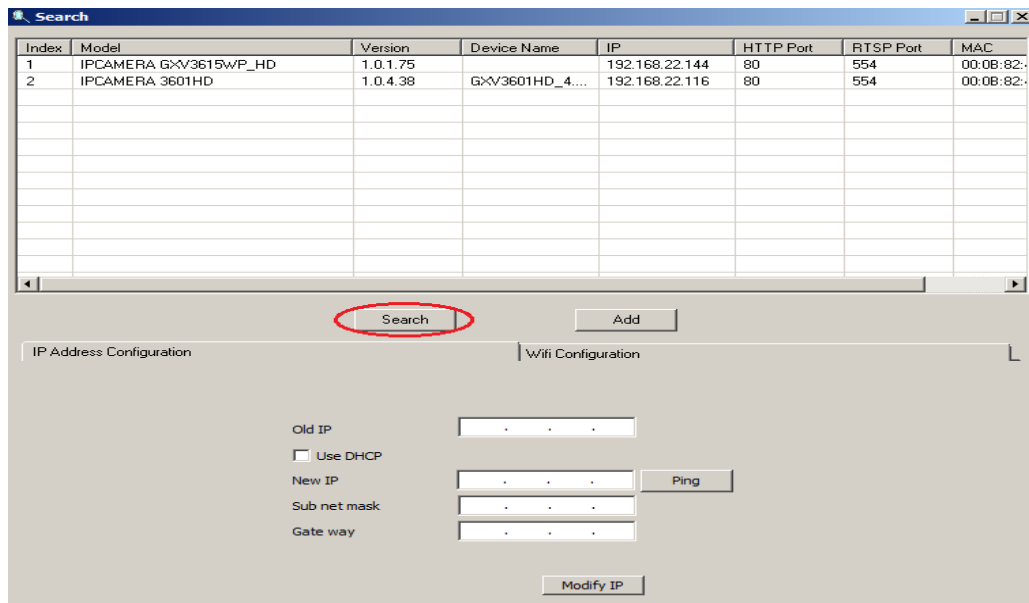

5. Double click the column of the detected camera, the browser will automatically open and link to the device IP and the web configuration page.
6. The browser will ask for plug-in or ActiveX if not installed, otherwise it will get to Home page and start to show the video captured by the camera (by default the camera enabled anonymous access)
7. Click “Configuration”, the browser will ask credentials to authorize configuration.
8. Enter the administrator user name and password to access the Web Configuration Interface, the default user name and password are both set to **admin**.
9. In step 6, IE will indicate that “This website wants to install the following add-on: GSViewerX.cab from Grandstream Networks Inc.” Please allow the installation.
10. Firefox and Chrome user need to download and install the plug-in to see the video, the plug-in is here:
http://www.grandstream.com/products/tools/surveillance/webcontrl_plugin.zip

NOTE:

- Please temporarily disable Antivirus or Internet Security Software and close all browsers when download and install the Grandstream Plug-in Software.

Connect to the Camera using Static IP

If no DHCP server in the network, or the camera does not get IP from DHCP server, user can connect the camera to a computer directly, using static IP to configure the camera.

The default IP, if no DHCP server; or DHCP offer time out (3 minutes), is **192.168.1.168**

1. Connect the computer RJ-45 via an Ethernet cable directly to the IP camera GXV3672_HD/FHD.
2. Configure the computer using Static IP: 192.168.1.XXX (1<XXX<255, but NOT 168) and configure the “Subnet mask” to “255.255.255.0”. Leave the “Default Gateway” to “Blank” like below:

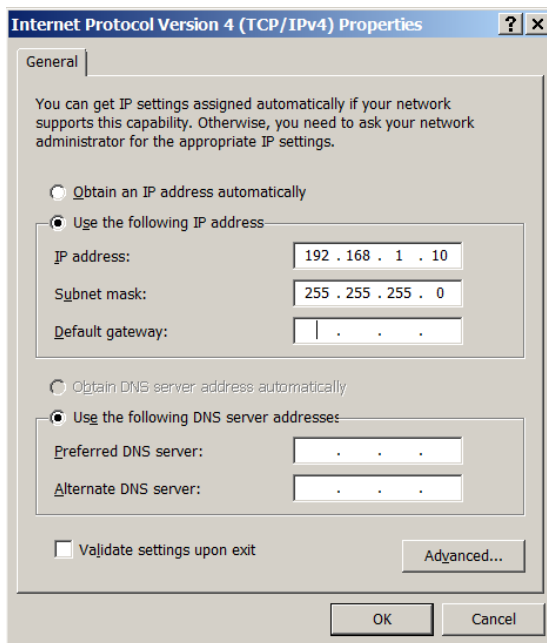

3. Power on the GXV3672_HD/FHD.
4. Start the IE or Firefox browser when the network connection is up.
5. Enter 192.168.1.168 in the address bar of the browser.
6. The browser will ask for plug-in or ActiveX if not installed, otherwise it will get to Home page and start to show the video captured by the camera (by default the camera enabled anonymous access)
7. Click “Configuration”, the browser will ask credentials to authorize configuration.
8. Enter the administrator user name and password to access the Web Configuration Interface, the default user name and password are both set to **admin**.
9. In step 6, IE will indicate that “This website wants to install the following add-on: GSViewerX.cab from Grandstream Networks Inc.”, allow the installation.
10. Firefox, Chrome user need to download and install the plug-in to see the video, the plug-in is here:
http://www.grandstream.com/products/tools/surveillance/webcontrl_plugin.zip

NOTE:

- Please temporarily disable Antivirus or Internet Security Software when download and install the Grandstream Firefox plug-in for video or “GSViewerX.cab” for Microsoft Internet Explorer.

GXV3672_HD/FHD HOME WEB PAGE

The Home Page of GXV3672_HD/FHD:

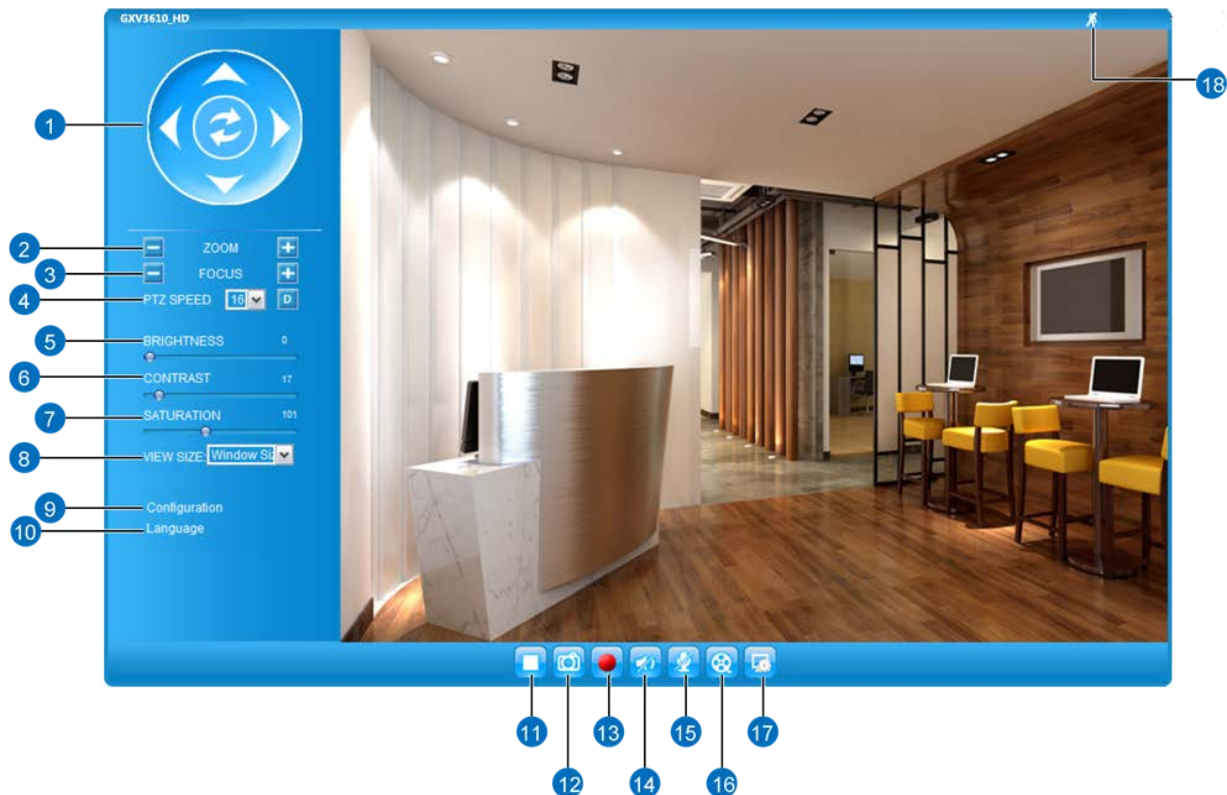

Figure 1: Home Page of GXV3672_HD/FHD

- | | |
|--|--|
| <ol style="list-style-type: none"> 1. Control Console: 2. ZOOM: 3. FOCUS: 4. PTZ SPEED/Default Button:
“D” 5. BRIGHTNESS: 6. CONTRAST: 7. SATURATION: 8. View Size: 9. Configuration 10. Language: 11. Play/Stop: 12. Capture (Snapshot): 13. Record: 14. Sound On/Off: 15. Talk: 16. Playback: 17. Local Configuration: 18. Motion Detection Alarm Indicator: | <p>PTZ Console controller for ePTZ function.</p> <p>Zoom in or Zoom out during ePTZ operation (Not Applicable).</p> <p>Adjust the focus of image (Not Applicable).</p> <p>Adjust the rotate speed of the control console (Not Applicable).</p> <p>“Default Button” to reset the video brightness, contrast and saturation value from (auto or manual) adjusted value to factory default value.</p> <p>Adjust the image or video brightness.</p> <p>Adjust the image or video contrast.</p> <p>Adjust the image or video saturation.</p> <p>Adjust the size of embedded video.</p> <p>Click to enter “Configuration Page” to configure the parameters of GXV3672_HD/FHD (Administration privilege required).</p> <p>Click to switch webpage language.
(Current supported: Chinese, English and Russian)</p> <p>Start/Stop playing the video stream at embedded webpage.</p> <p>Click to capture and save a snapshot of current video frame displayed.
Default directory: C:\Capture</p> <p>Click to Start/Stop record of current video stream into a file.
Default directory: C:\Record</p> <p>Toggle to listen/stop the sound from camera microphone. (N/A on 8mm model)</p> <p>Toggle to talk to camera speaker if provided. (PC microphone and related speaker hardware required. N/A on 8mm model)</p> <p>Playback recorded video files</p> <p>Click to configure the file path of snapshot and recorded video files.
Also adjust the video delay or smoothness.</p> <p>If motion detection alarm triggered, the indicator will flash in red (if configured). Click the indicator icon to turn off the alarm indication.</p> |
|--|--|

GXV3672_HD/FHD Configuration & Language Page

- When click the “Configuration” tab, web page will link to page to configure the related parameters of the GXV3672_HD/FHD.
- There are two big categories of settings: Basic Settings and Advanced Settings. Details will be illustrated in the later Chapter.
- When click the “Language” tab, supported languages will be displayed in Figure 2. Click to select the related webpage display language.



Figure 2: Web Language Switch

- Currently firmware only support: English (default), Simplified Chinese and Russian.

BASIC SETTINGS EXPLANATION

System Settings Page

This page allow user to configure the system settings of GXV3672_HD/FHD.

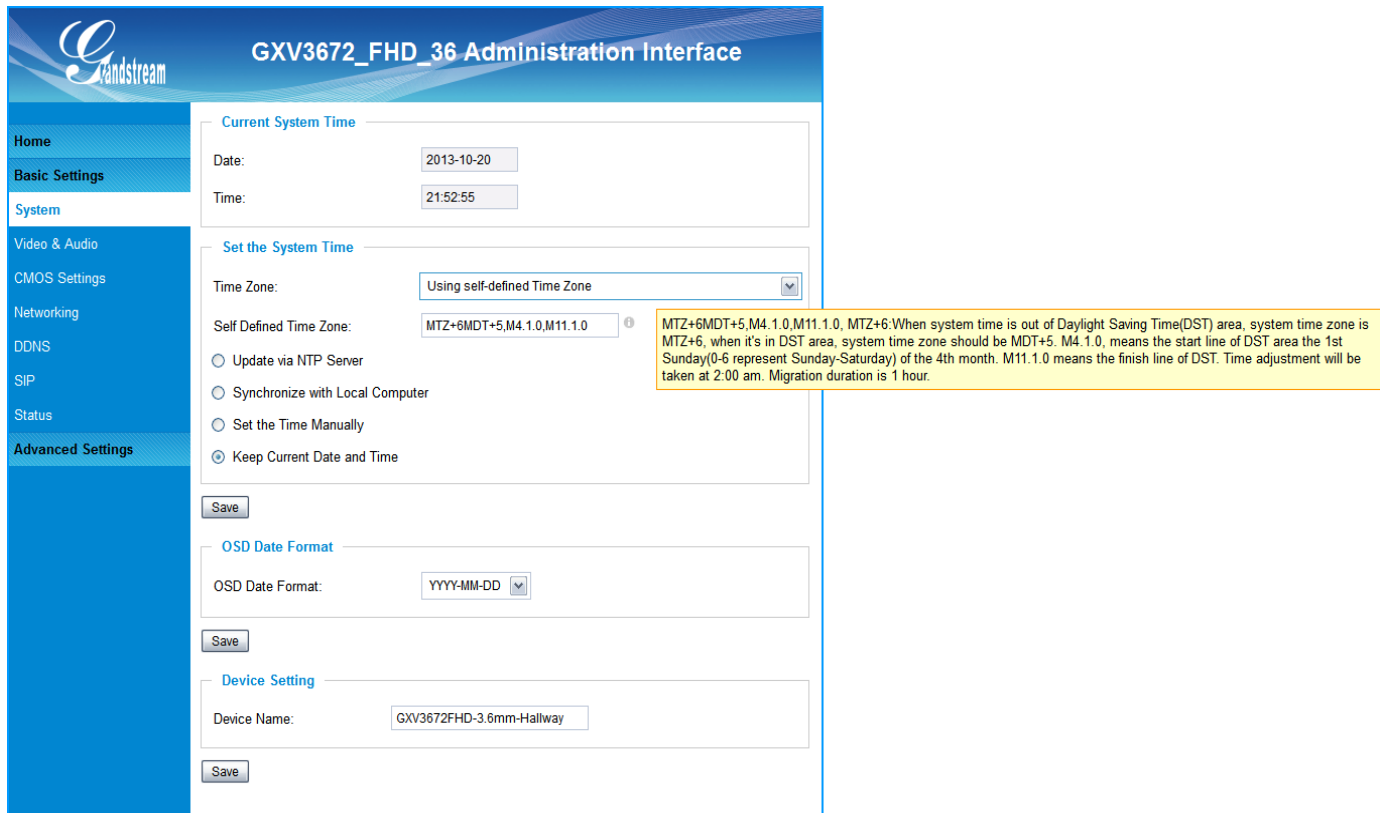

Figure 3: System Settings Page

- **Current System Time:** Display time current system is running at
- **Set the System Time:** Configure the time system is running.
 - **Time Zone:** Select from pull down menu the time zone unit located
 - **Self-Defined Time Zone:** Use the self-defined time zone for automatic daylight saving time adjustment. Format please refer to the “help over mouse”
 - **Update via NTP Server:** Synchronize time using NTP protocol with a Time Server over the Internet cloud (*)
 - **Synchronize with Local Computer:** Synchronize time with local computer
 - **Set the Time Manually:** Manually input the time
 - **Keep Current D/T:** Select to use camera current displayed time
- **OSD Date Format:** Pull down to select date format displayed on video screen
- **Device Name:** The name of device which will be shown in the result of “Search Tool” of GSurf_Pro VMS program.

NOTE:

(*) If select this option, a valid DNS server must be preconfigured under **Basic Settings** → **Networking**

➤ **Save** button has to be clicked to save all the changes made to the device.

Video & Audio Setting Page

This page allows user to configure the video and audio related settings.

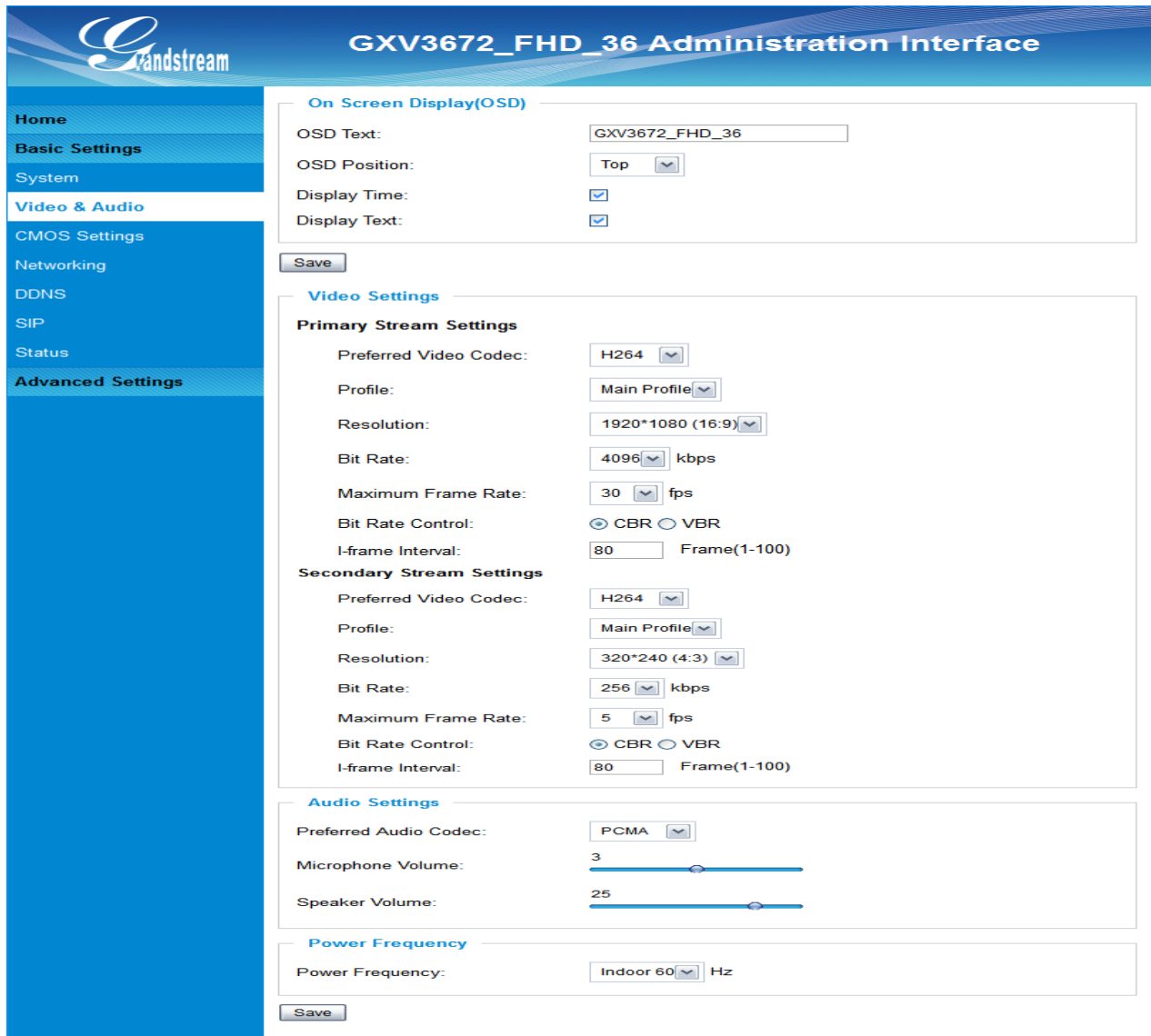

The screenshot shows the 'GXV3672_FHD_36 Administration Interface' with a sidebar menu on the left containing: Home, Basic Settings, System, Video & Audio (selected), CMOS Settings, Networking, DDNS, SIP, Status, and Advanced Settings. The main content area is divided into several sections:

- On Screen Display(OSD):** Includes fields for OSD Text (GXV3672_FHD_36), OSD Position (Top), Display Time (checked), and Display Text (checked). A Save button is present.
- Video Settings:**
 - Primary Stream Settings:** Preferred Video Codec (H264), Profile (Main Profile), Resolution (1920*1080 (16:9)), Bit Rate (4096 kbps), Maximum Frame Rate (30 fps), Bit Rate Control (radio buttons for CBR and VBR, with CBR selected), I-frame Interval (80 Frame(1-100)).
 - Secondary Stream Settings:** Preferred Video Codec (H264), Profile (Main Profile), Resolution (320*240 (4:3)), Bit Rate (256 kbps), Maximum Frame Rate (5 fps), Bit Rate Control (radio buttons for CBR and VBR, with CBR selected), I-frame Interval (80 Frame(1-100)).
- Audio Settings:** Preferred Audio Codec (PCMA), Microphone Volume (slider at 3), and Speaker Volume (slider at 25).
- Power Frequency:** Power Frequency (Indoor 60 Hz). A Save button is present.

Figure 4-1: Video & Audio Settings Page

- **On Screen Display (OSD):** Display time stamp and text on the video screen.
 - OSD Text: Inputted text (to identify the camera) shown on the screen.
 - OSD Position: Show the OSD in either top or bottom position on screen.
 - Display Time: When checked, time stamp will display on video screen
 - Display Text: When checked, inputted text will display on video screen.
- **Audio Settings:**
 - Preferred Audio Codec: PCMU, PCMA, AAC supported.
 - Microphone Volume: Slide to adjust microphone gain.
 - Speaker Volume: Slide to adjust the speaker volume.
- **Power Frequency:** Select correct local power frequency to avoid video flicking effect under fluorescence light condition. Default is Outdoor.

Video Settings

Primary Stream Settings

Preferred Video Codec: H264

Profile: Main Profile

Resolution: 1920*1080 (16:9)

Bit Rate: 4096 kbps

Maximum Frame Rate: 25 fps

Bit Rate Control: CBR VBR

Image Quality: Normal

I-frame Interval: 80 Frame(1-100)

Secondary Stream Settings

Preferred Video Codec: H264

Profile: Main Profile

Resolution: 320*240 (4:3)

Bit Rate: 256 kbps

Maximum Frame Rate: 5 fps

Bit Rate Control: CBR VBR

Image Quality: Normal

I-frame Interval: 80 Frame(1-100)

Figure 4-2: Video & Audio Settings Page

- **Primary Stream Settings:**
 - Preferred Video Codec: MJPEG and H.264 supported, H.264 recommended.
 - Profile: H.264 profile selection. Default is “Baseline.” (N/A on 8mm model)
 - Resolution: The video resolution in pixels used in video of camera
 - Bit Rate: video bit rate used
 - Maximum Frame Rate: Maximum frame rate used. More data if big frame used
 - Bit Rate Control: Constantly bit rate, or variable bit rate
 - Image Quality: Image quality used when Variable Bit Rate used
 - I-frame Interval: I-frame interval
- **Secondary Stream Settings:** Same as primary steam.

NOTE:

- *H.264 suggested if camera needs to be viewed via Internet.*
- *If MJPEG selected, reduce max. frame rate to min. value to save bandwidth and get better image*
- *Grandstream IP Camera provides two video streams, user can use them with flexibility. For example, the high-resolution stream for local recording; another low or high resolution for remote monitoring; or vice versa depending application scenarios.*
- *Use below link to calculate bandwidth and storage before installation*
<http://www.grandstream.com/support/tools/bandwidth-storage-calc>

CMOS Settings Page

This page allows user to adjust the CMOS parameters:

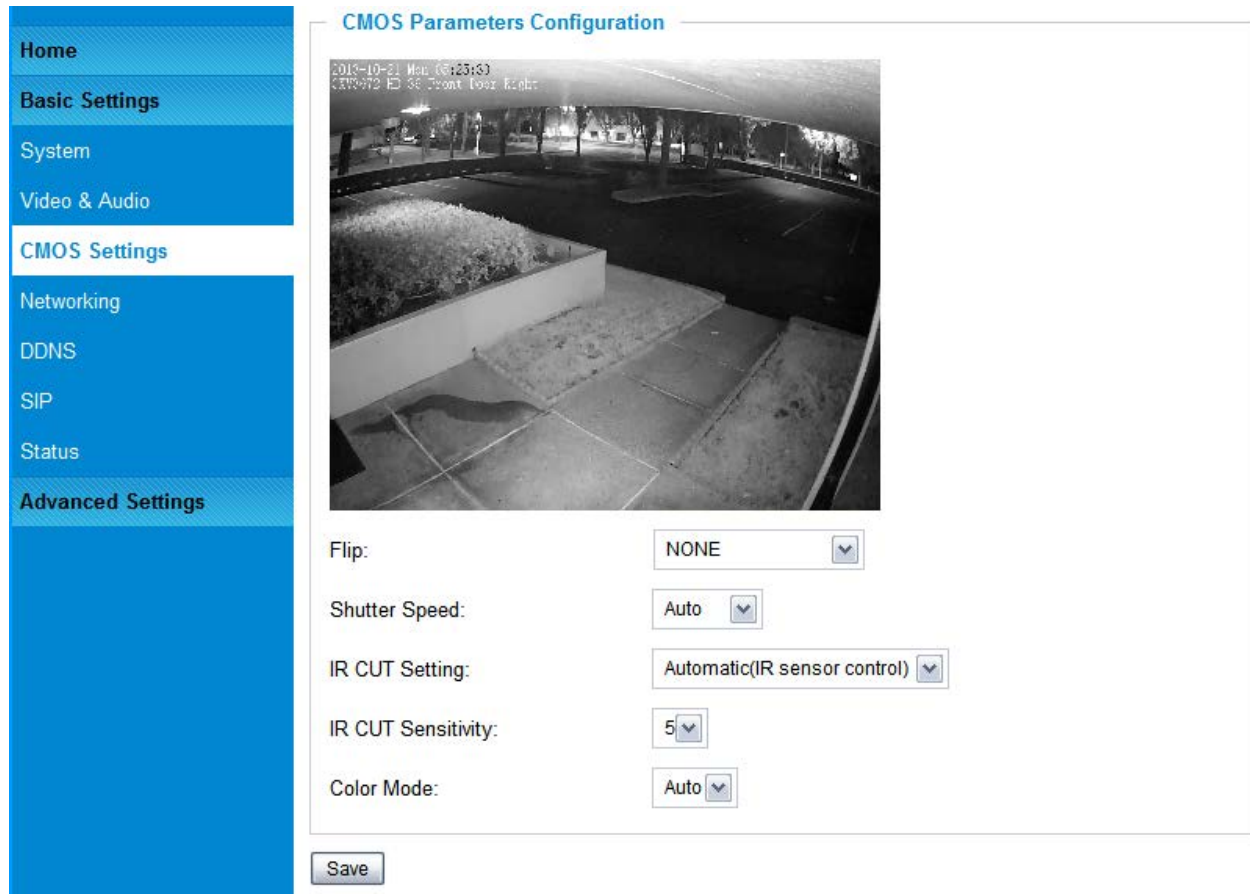

Figure 5: CMOS Settings Page

- **Flip:** Pull down to choose video flip, either vertically or horizontal or both.
- **Shutter Speed:** Camera Shutter Speed. There are 10 options, with Auto, 1/30, 1/60, 1/125, 1/250, 1/500, 1/1000, 1/2000, 1/5000 and 1/10000
- **IR CUT Setting:** Manual or Automatic (IR Sensor controlled mechanical IR CUT)
- **IR CUT Sensitivity:** Sensitivity of IR CUT to be triggered; 5 levels total.
- **Color Mode:** Camera Color Mode. There are three options: Color, Black/White, Auto (Default).

NOTE:

- *Auto option recommended for Shutter Speed, IR CUT Setting and Color Mode.*

Networking Setting Page

This page allows user to configure network related parameters:

IP Address Configuration

Dynamically Assigned via DHCP

Statically Configured as:

IP Address:

Subnet Mask:

Default Gateway:

DNS Configuration

Obtain DNS Server Address Automatically

Use the Following DNS Server Address:

Primary DNS Server:

Secondary DNS Server:

HTTP

HTTP Port:

Figure 6: Networking Setting Page

- **IP Address Configuration:**
 - Dynamically Associated via DHCP: Camera IP address configuration
Default setting, DHCP server assign IP to camera.
 - Statically Configured as: Static IP address configuration
- **DNS Configuration:** DNS server IP. Must be configured if using static IP.
- **HTTP:** Web access TCP port, default 80.

NOTE:

- *If camera behind SOHO router with port forwarding configuration for remote access, static IP or static DHCP has to be used to avoid IP address change after router reboot.*
- *TCP port above 5000 suggested if port forwarding HTTP remote access, due to some ISP would block port 80 inbound traffic. For example, change the default HTTP port from 80 to 8088, to make sure the port forwarding not likely be blocked.*
- *In addition to HTTP port, RTSP port also required to be configured for port forwarding, in order for remote party viewing the H.264 video.*
- *If change the default port from TCP 80 to port “A”, then RTSP port should be “2000+A”. Both TCP port “A” and “2000+A” should be configured for port forwarding in the router. For example, the HTTP port changed to 8088, the RTSP port should be 10088, both 8088 and 10088 should be configured for port forwarding in order for remote camera video access.*

DDNS Settings Page

This page allows user to configure dynamic DNS related parameters:



Figure 7: DDNS Setting Page

- **DDNS Active:** Enable DDNS by check this field.
- **DDNS ISP Type:** Select the DDNS service provider from the pull-down menu list
- **Self-Define DDNS Address:** Input the self-defined DDNS address
- **Site Name:** DDNS site name
- **DDNS Account:** DDNS account name
- **DDNS Password:** DDNS password
- **STUN Server:** Stun server FQDN or IP. If device behind a non-symmetric router, STUN server can help to penetrate & resolve NAT issue.

SIP Setting Page

This page allows user to configure SIP related parameters.

GXV3672_HD/FHD can be configured as SIP endpoint to call out when alarm triggered; or allow permitted number to call in to check the video if Grandstream video IP phone is used.

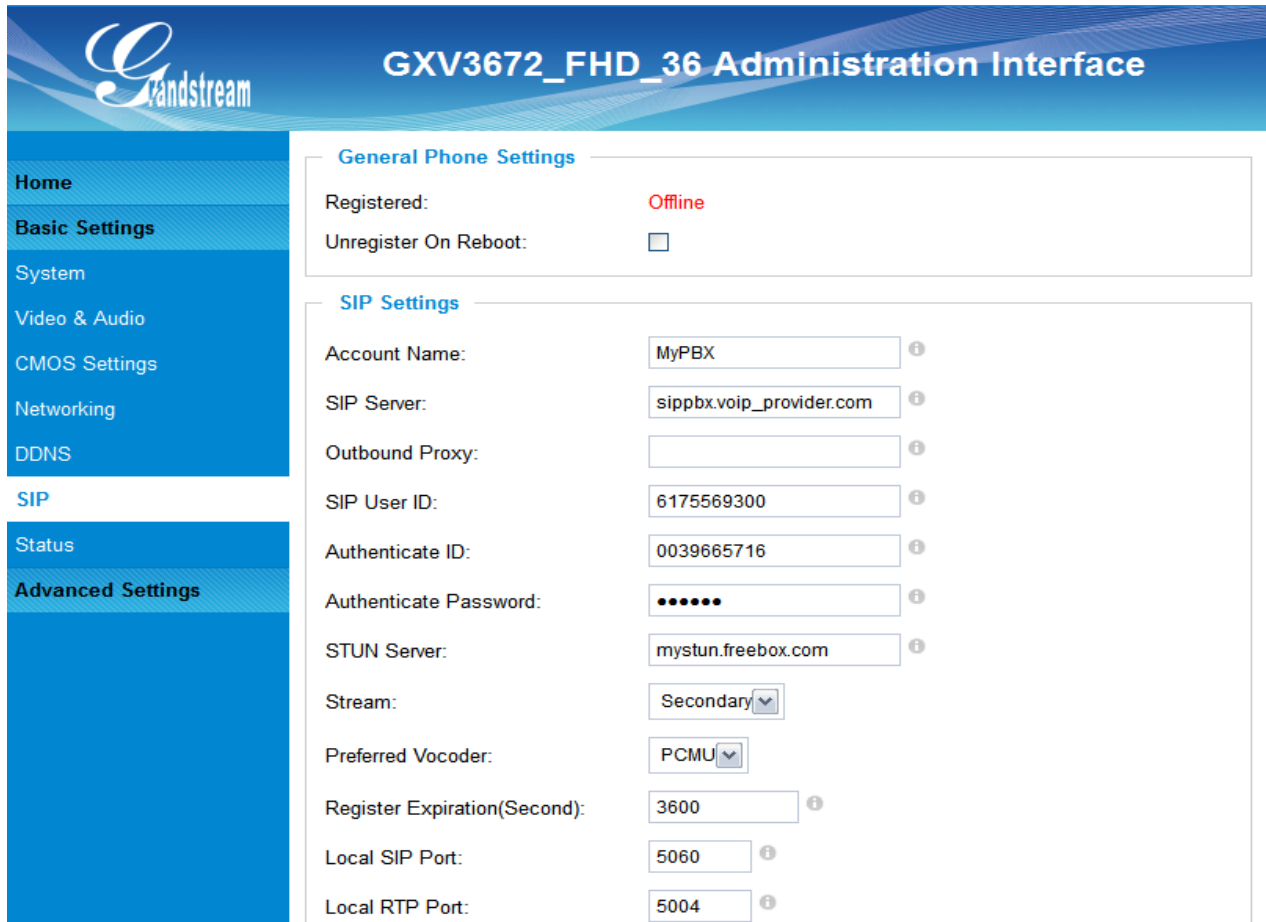

The screenshot shows the 'GXV3672_FHD_36 Administration Interface' with a sidebar on the left containing navigation options: Home, Basic Settings, System, Video & Audio, CMOS Settings, Networking, DDNS, SIP, Status, and Advanced Settings. The main content area is divided into two sections: 'General Phone Settings' and 'SIP Settings'.

General Phone Settings

- Registered: Offline
- Unregister On Reboot:

SIP Settings

- Account Name: MyPBX
- SIP Server: sippbx.voip_provider.com
- Outbound Proxy:
- SIP User ID: 6175569300
- Authenticate ID: 0039665716
- Authenticate Password: ••••••
- STUN Server: mystun.freebox.com
- Stream: Secondary
- Preferred Vocoder: PCMU
- Register Expiration(Second): 3600
- Local SIP Port: 5060
- Local RTP Port: 5004

Figure 8-1: SIP Setting Page

- **Registered:** SIP registration status. Display “Online” in Green, “Offline” in Red.
- **Unregistered on Reboot:** If checked and server support, reboot camera will unbind all registration in same SIP account.
- **Account Name:** SIP account name
- **SIP Server:** FQDN or IP of SIP server from VoIP service provider
- **Outbound Proxy:** IP or FQDN of Outbound proxy server, helps penetrate NAT/Firewall
- **SIP User ID:** SIP username, or telephone number from ITSP
- **Authenticate ID:** Authenticate ID used by SIP proxy
- **Authenticate Password:** Authenticate password used by SIP proxy
- **STUN Server:** STUN server used to resolve NAT.
- **Stream:** Which stream used for SIP call.
- **Preferred Vocoder:** Audio codec used for SIP call. (N/A on 8mm model)
- **Registration Expiration:** Registration expiration time, default 3600 seconds
- **Local SIP Port:** Local SIP port, default 5060
- **Local RTP Port:** Local RTP port for media, default 5004

Auto On-Hook Timer:	<input type="text" value="300"/>	?
Disable Audio in SIP Call:	<input type="checkbox"/>	?
Enable Keep Alive	<input type="checkbox"/>	
Accept Direct IP Call:	<input checked="" type="checkbox"/>	
Enable White List Number Filter:	<input type="checkbox"/>	?
Enable two-way Audio Warning Mode:	<input checked="" type="checkbox"/>	?
SIP Proxy Compatibility Mode:	<input type="checkbox"/>	?
Self-defined Warning Audio:	<input type="button" value="Upload"/>	<input type="button" value="Delete"/>

Phone List		
Phone Number	Remark Name	Remove
<input type="text" value="6179114110"/>	<input type="text" value="Local Police"/>	<input type="button" value="Add..."/>

White List	
Phone Number	Remove
<input type="text" value="6175669300"/>	<input type="button" value="Add..."/>

Figure 8-2: SIP Setting Page

- **Auto On-hook Timer:** Auto On Hook timer, default 300 seconds
- **Disable Audio in SIP Call:** Checked to disable audio for SIP call. (N/A on 8mm model)
- **Enable Keep Alive:** Checked to enable, help NAT resolution
- **Accept Direct IP Call:** Check to accept peer-to-peer IP call.
- **Enable White List Number Filter:** Check to allow only white list number to call in, for security
- **Enable two-way Audio Warning:** Check to enable two-way audio warning. (N/A on 8mm model)
- **SIP Proxy Compatibility Mode:** Check to enable more proxy compatibility with cost of bandwidth
- **Self-define Warning Audio:** Upload self-defined warning message audio (follow the format)
- **Phone List/Phone Number:** Callee or call receiver number when alarm call triggered.
- **White List/Phone Number:** Phone numbers allowed to call into the camera.

NOTE:

- *GXV3672_HD/FHD requires external microphone connected to internal module to support audio calls*

Status Page

This page shows the GXV3672_HD/FHD operation status:



The screenshot shows the 'GXV3672_FHD_36 Administration Interface' with a left-hand navigation menu and three main status sections: System Statistics, Network Status, and Camera Type. The 'SIP Registered' status is highlighted in red as 'Offline'.

Section	Parameter	Value
System Statistics	Product Model:	GXV3672_FHD_36
	Hardware Version:	V1.0A
	Part Number:	9670005310A
	Bootloader Version:	1.0.2.37
	Core Version:	1.0.2.37
	Base Version:	1.0.2.37
	Firmware Version:	1.0.2.37
System Up Time Since:		23 hours 47 minutes
Network Status	MAC Address:	00:0B:82:57:93:5A
	LAN IP Address:	10.0.0.199
	LAN Subnet Mask:	255.255.255.0
	LAN Default Gateway:	10.0.0.1
	DDNS Status:	Disabled
	SIP Registered:	Offline
IR CUT Status		Night
Camera Type		Aptina, AR0331 Pixels 2048*1536

Figure 9: Status Page

NOTE:

- IR CUT Status N/A on 8mm model
- When SIP account registered, the status will display “Online” in Green.
- When SIP account unregistered, the status will display “Offline” in Red, as below.

SIP Registered: Offline

ADVANCED SETTINGS EXPLANATION

User Management Page

This page allows user to do user management:

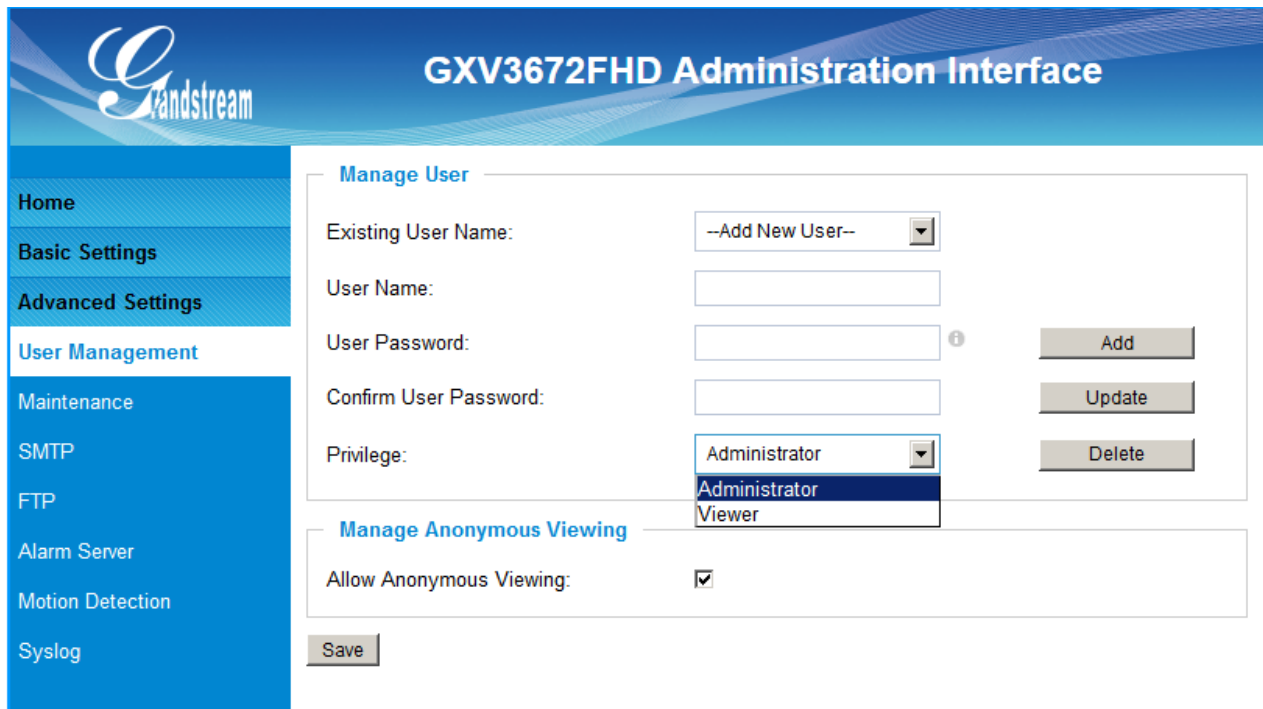

The screenshot shows the 'GXV3672FHD Administration Interface' with a sidebar menu on the left containing: Home, Basic Settings, Advanced Settings, User Management (highlighted), Maintenance, SMTP, FTP, Alarm Server, Motion Detection, and Syslog. The main content area is titled 'Manage User' and includes the following fields and buttons:

- Existing User Name:** A dropdown menu with the option '--Add New User--' selected.
- User Name:** A text input field.
- User Password:** A text input field with an information icon (i) to its right.
- Confirm User Password:** A text input field.
- Privilege:** A dropdown menu with 'Administrator' selected, and 'Administrator' and 'Viewer' visible in the list.
- Buttons:** 'Add', 'Update', and 'Delete' buttons are positioned to the right of the password and privilege fields.

Below the 'Manage User' section is the 'Manage Anonymous Viewing' section, which includes:

- Allow Anonymous Viewing:** A checkbox that is checked.
- Save:** A button at the bottom left of the form.

Figure 10: User Management Page

- **Existing User Name:** Allow revise existing user or add new user
- **User Name:** The name of user need to be revised
- **User Password:** New password if revise password
- **Confirm User Password:** Re-enter the new password for verification
- **Privilege:** Choose user privilege
- **Allow Anonymous Viewing:** When checked, no security enhanced. Any person can view the camera if knowing the IP or FQDN of the camera, but can NOT change anything, just view ONLY.

Maintenance Page

This page allows user to maintain the camera:



Figure 11: Maintenance Page

- **Restart:** When clicked, the camera will reboot or restart
- **Restore:** When clicked, the camera will be reset to factory default, wiping out all the configurations (except IP address)
- **Upgrade via:** Upgrade firmware via TFTP, HTTP or HTTPS
- **Firmware Server Path:** Server path holding the firmware
- **Config Server Path:** Server path holding the configuration file (auto provisioning)
- **XML ConfigFile Password:** Password for encrypt the XML based configuration file
- **Automatic Upgrade Interval (Minutes):** Time interval for automatic upgrade, default 10080
- **Automatic Upgrade:** Checked to enable automatic firmware upgrade and provisioning.

NOTE:

- *Only XML based automatic provisioning is supported by GXV3672_HD/FHD.*

SMTP Setting Page (Email Alarm)

This page allows user to configure email client to send out email when alarm triggered:

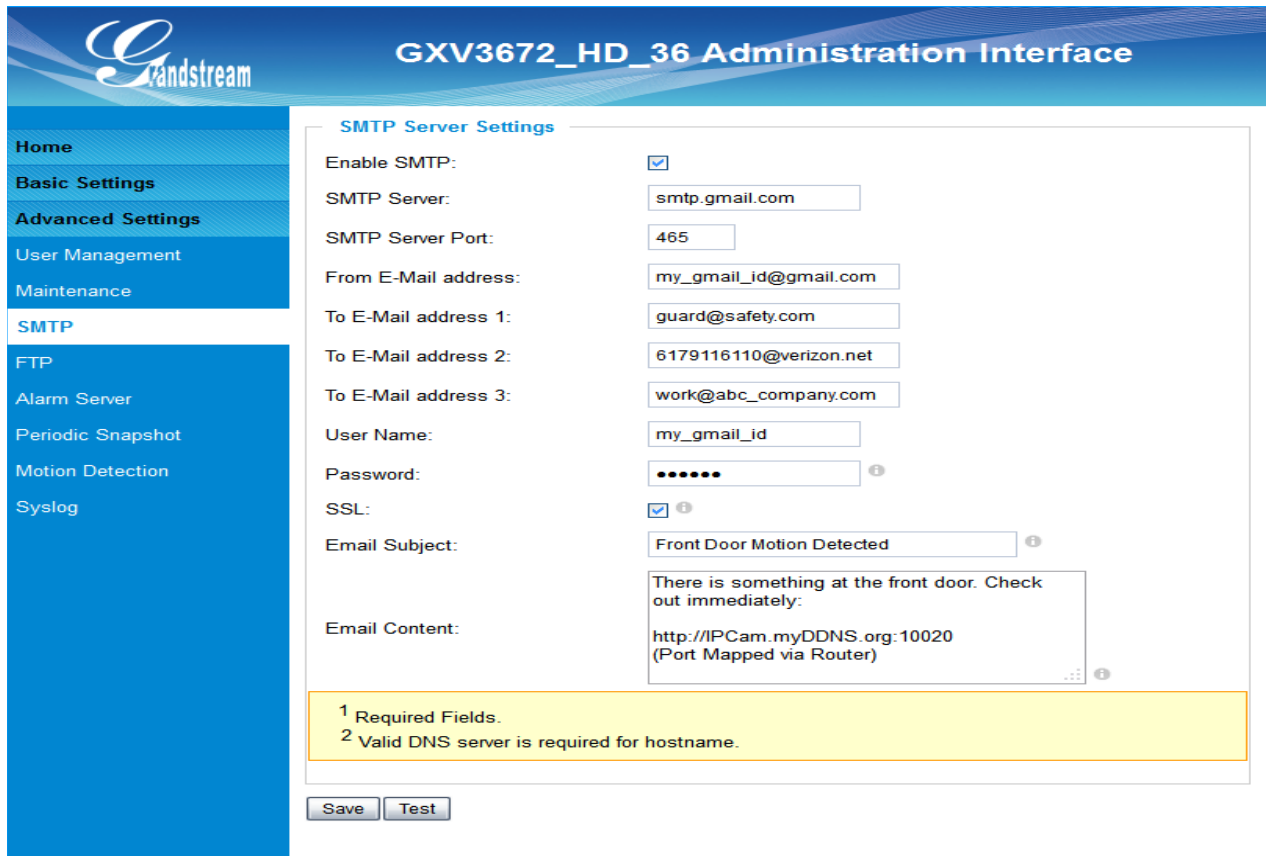

SMTP Server Settings

Enable SMTP:

SMTP Server:

SMTP Server Port:

From E-Mail address:

To E-Mail address 1:

To E-Mail address 2:

To E-Mail address 3:

User Name:

Password:

SSL:

Email Subject:

Email Content:

There is something at the front door. Check out immediately:
http://IPCam.myDDNS.org:10020
(Port Mapped via Router)

1 Required Fields.
2 Valid DNS server is required for hostname.

Figure 12: SMTP Setting Page

- **Enable SMTP:** When checked, email client is enabled.
- **SMTP Server:** SMTP Email Server IP or Domain Name
- **SMTP Server Port:** Port number used by server to send email
- **From Email address:** The email address of alarm email sending from, usually client email ID
- **To E-Mail address:** The email address to receive the alarmed email, total 3 included.
- **User Name:** Email client User ID
- **Password:** Email client password
- **SSL:** Check if the SMTP email server requires SSL
- **Email Subject:** Customizable email subject for user convenience
- **Email Content:** Customizable email body for user convenience

NOTE:

- Click “Save” to save the email configuration information.
- Click “Test” after configuration, if setting is correct, a test email will send out and “Test successful!” yellow bar will display like below

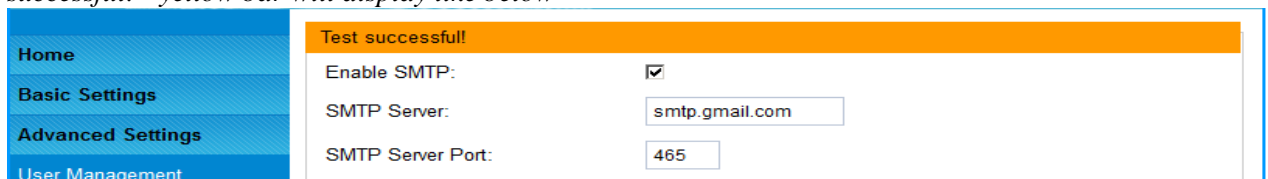

Test successful!

Enable SMTP:

SMTP Server:

SMTP Server Port:

FTP Settings Page (Upload Alarm)

This page allows user to configure FTP parameters to upload the alarm or video recording:

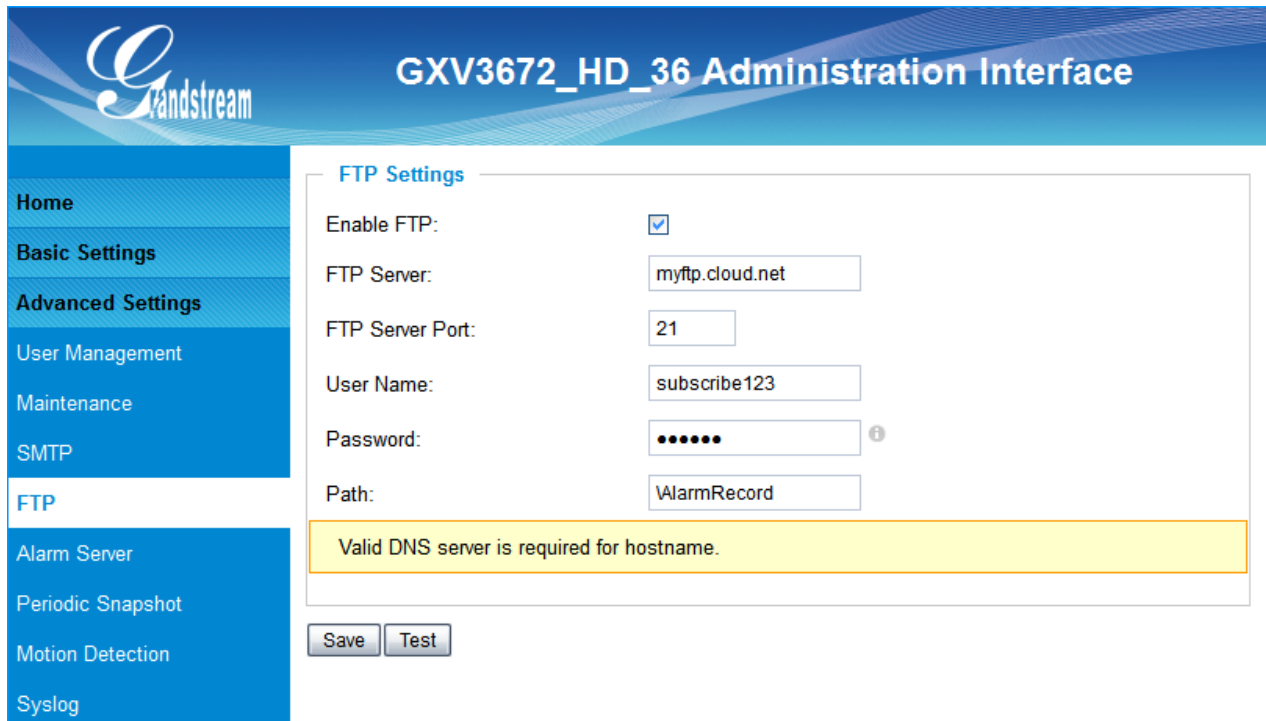

Figure 13: FTP Setting Page

- **Enable FTP:** When checked, built-in FTP client is enabled.
- **FTP Server:** IP or Domain name of FTP site or server
- **FTP Server Port:** TCP port for FTP server, default port number 21
- **User Name:** FTP server User ID
- **Password:** FTP server user password
- **Path:** Path in the server where upload files are stored.

NOTE:

- Click “Save” to save the FTP configuration information.
- Click “Test” after configuration, if setting is correct, a test FTP operation will be performed and “Test successful!” yellow bar will display if the operation is successful.

Alarm Server Settings Page (Upload Alarm to supported VMS or HTTP Server)

This page allows user to configure alarm HTTP server to upload alarms:

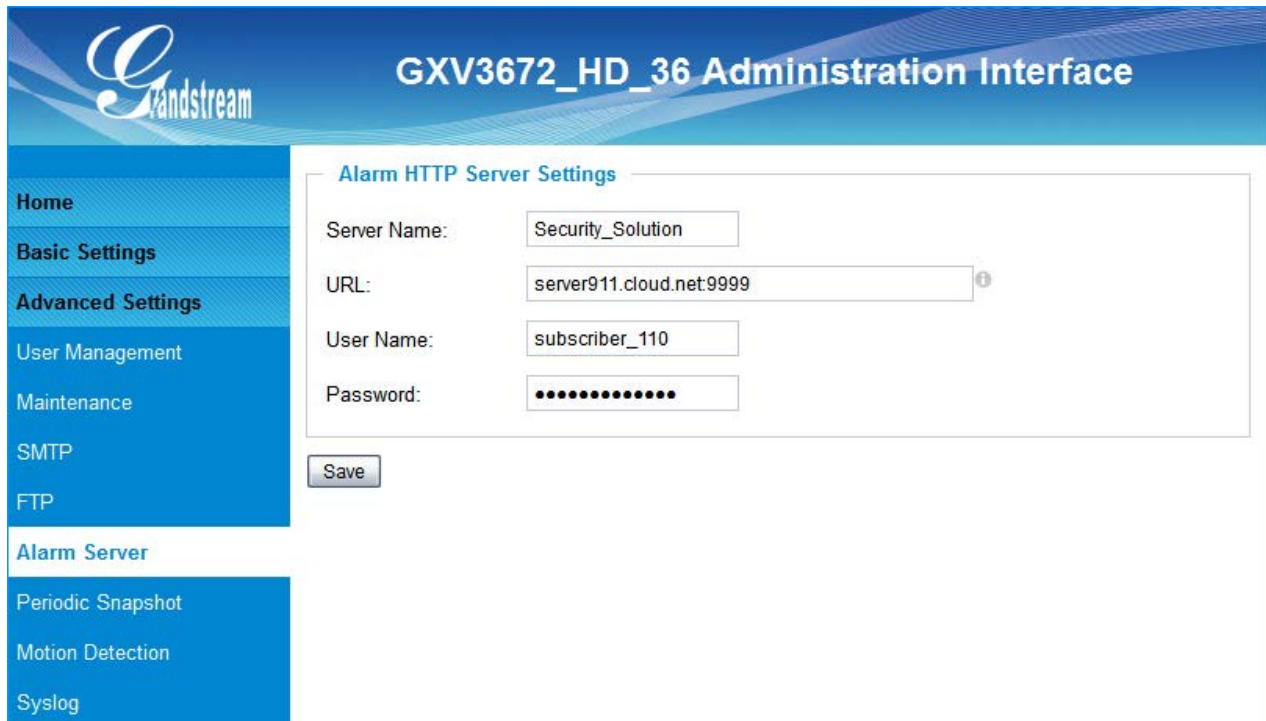

Alarm HTTP Server Settings

Server Name:

URL:

User Name:

Password:

Figure 14: Alarm HTTP Server Setting Page

- **Server Name:** The name of HTTP server or VMS system
- **URL:** URL of the Server
- **User Name:** User ID from that Server
- **Password:** Password for that User ID

NOTE:

- *Grandstream provide HTTP API to help third party companies by using HTTP server or VMS to develop further solutions for their customers.*

http://www.grandstream.com/products/surveillance/general/documents/grandstream_http_api.pdf

- *Grandstream IP Camera and DVS (including GXV3672_HD/FHD) are ONVIF certified.*

Periodic Snapshot

This page allows user to setup periodic snapshots: (N/A on 8mm model)

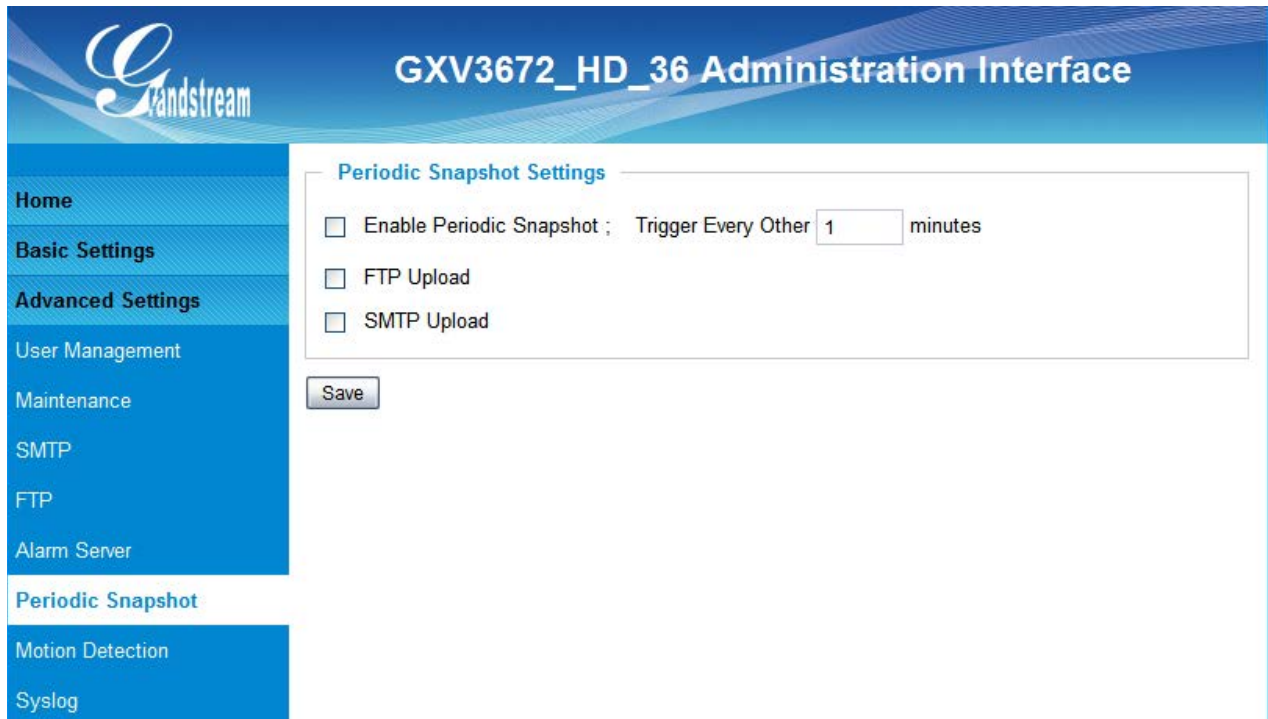

GXV3672_HD_36 Administration Interface

Periodic Snapshot Settings

Enable Periodic Snapshot ; Trigger Every Other minutes

FTP Upload

SMTP Upload

Figure 15: Period Snapshots Page

- **Enable Periodic Snapshot:** Enable and set trigger interval for snapshot
- **FTP Upload:** If checked, enables FTP upload for periodic snapshot
- **SMTP Upload:** If checked, enables SMTP upload for periodic snapshot

Motion Detection Configuration Page (Set Alarm)

This page allows user to configure motion detection to trigger alarms:



The screenshot displays the 'GXV3672_HD_36 Administration Interface' with a sidebar menu on the left containing: Home, Basic Settings, Advanced Settings, User Management, Maintenance, SMTP, FTP, Alarm Server, Periodic Snapshot, Motion Detection (highlighted), and Syslog.

Motion Detection Region Settings

2013-10-20 Sat 23:49:57
GXV3672 HD 36 Front Door Right

Enable Motion Detection
 Show Motion Detection Regions
 0 Select a Region
 50 Sensitivity

Alarm Action

Record Video From Pre Alarm Up to 10 seconds to After Alarm Up to 30 seconds
 Voice Alarm to SIP Phone
 Upload to Alarm Center
 Upload to Alarm HTTP Server
 Record Video and Upload to FTP Server
 Email and FTP upload JPEG
 Pre Alarm Up to 5 seconds to After Alarm Up to 5 seconds

Motion Detection Time Schedule

Region ID	Date	Start Time	End Time	
0	Everyday	00:00	23:59	<input type="button" value="Add"/>
0	Everyday	00:00	23:59	<input type="checkbox"/>

Check All

Figure 16-1: Motion Detection Configuration Page

- **Enable Motion Detection:** When checked, motion detection enabled.
- **Show Motion Detection Regions:** When checked, motion detection region with number will be displayed as a white rectangle in the screen. When “Edit” clicked, the rectangle will become Red, as shown in Figure 16-1.
- **Select a Region:** Pull down to select and configure alarm region, altogether 16 alarm region available, from 0 to 15.
- **Sensitivity:** Select configured alarm region number, input number for sensitivity to trigger alarm, 100 is the maximum sensible value.

Alarm Action:

- **Record Video From.....** Allow user to configure how long pre/post alarm trigger moment, the video to be captured by the camera.
- **Voice Alarm to SIP Phone:** When checked and SIP proxy configured and IPCam registered, SIP alarm call will be made to pre-configured number.
- **Upload to Alarm Center:** When checked, the alarm video will be transferred to Alarm Center, like Grandstream free GSurf_Pro VMS software.
- **Upload to Alarm HTTP Server** When checked, the alarm will be sent to Alarm HTTP Server. Third Party Server also can be used via GS HTTP API
- **Record Video and Upload...:** When checked and FTP server configured, the recorded video will be uploaded to the configured FTP server.
- **Email and FTP upload JPEG:** When checked, snapshots of trigger moment will be emailed to pre-configured email account and also uploaded to FTP server if configured.

NOTE:

- Grandstream free GSurf_Pro VMS software can be downloaded here:
http://www.grandstream.com/products/tools/surveillance/gsurf_pro.zip

Motion Detection Time Schedule:

This page allows user to configure Motion Detection Operation Schedule:

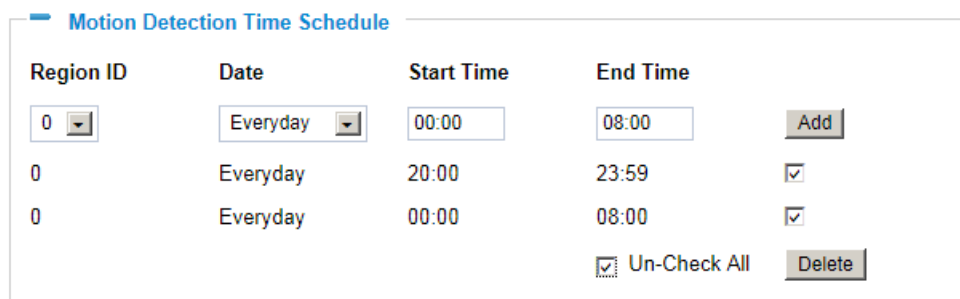

The screenshot shows a configuration page titled "Motion Detection Time Schedule". It features a table with columns for Region ID, Date, Start Time, and End Time. There are also "Add", "Un-Check All", and "Delete" buttons.

Region ID	Date	Start Time	End Time	
0	Everyday	00:00	08:00	Add
0	Everyday	20:00	23:59	<input checked="" type="checkbox"/>
0	Everyday	00:00	08:00	<input checked="" type="checkbox"/>
				<input checked="" type="checkbox"/> Un-Check All
				Delete

Figure 16-2: Motion Detection Schedule Configuration Page

- As shown in Figure 16-2, user can configure the Motion Detection Region with related Start and Stop time to control the motion detection operation.

Syslog Settings Page (Troubleshooting)

This page allows user to enable the Syslog to help troubleshooting problems:

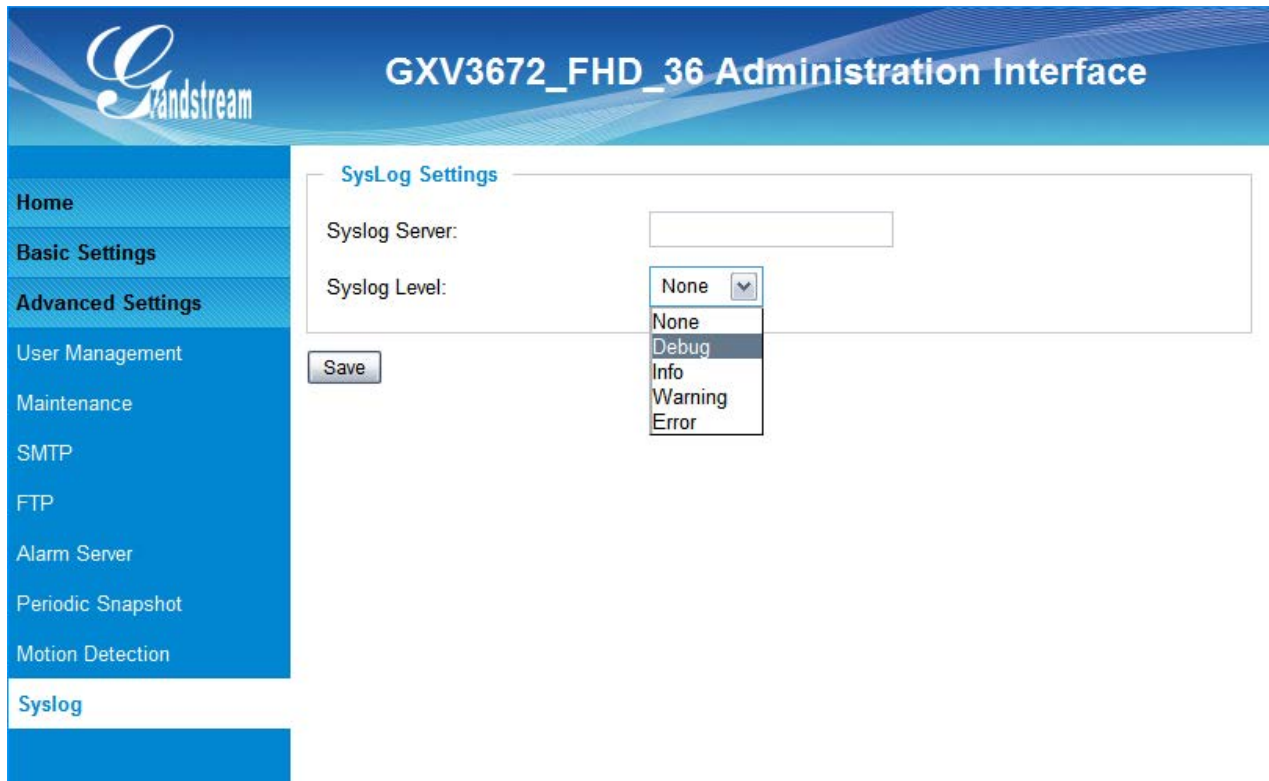

Figure 17: Alarm Server Setting Page

- **Syslog Server:** Syslog server IP or Domain Name
- **Syslog Lever:** Lever of syslog message sent to the syslog server: *None, Debug, Info, Warning, Error.*

Software Upgrade

This page allows user to configure firmware upgrade.

Software upgrade can be done via TFTP, HTTP or HTTPS. The corresponding configuration settings are in the ADVANCED SETTINGS configuration page.

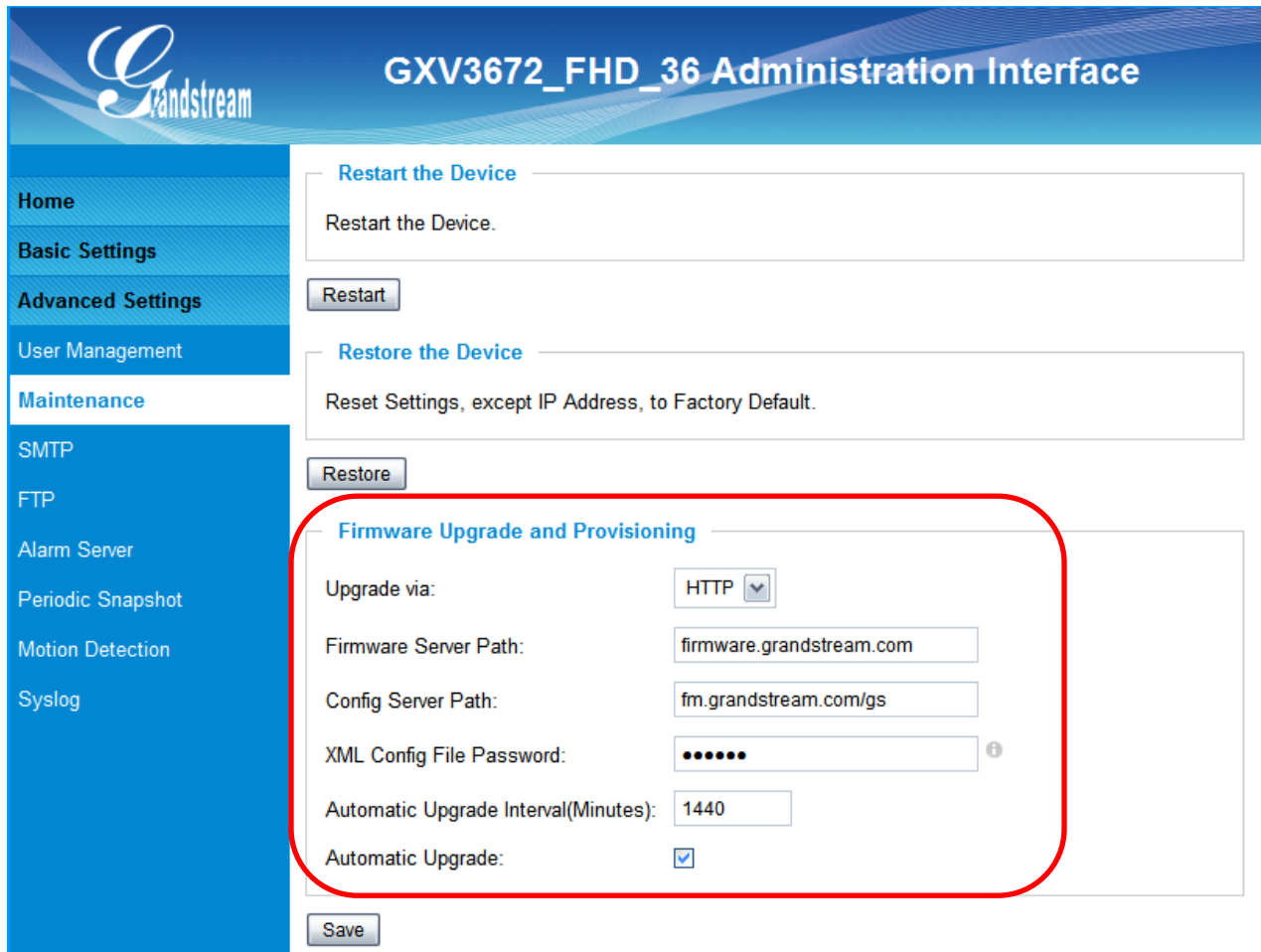

Restart the Device
Restart the Device.
Restart

Restore the Device
Reset Settings, except IP Address, to Factory Default.
Restore

Firmware Upgrade and Provisioning

Upgrade via: HTTP

Firmware Server Path: firmware.grandstream.com

Config Server Path: fm.grandstream.com/gs

XML Config File Password: ●●●●●●

Automatic Upgrade Interval(Minutes): 1440

Automatic Upgrade:

Save

Figure 18: Firmware Upgrade and Provisioning

NOTE:

- Grandstream recommends end-user use the Grandstream HTTP server: *firmware.grandstream.com*
- For large companies, we recommend to maintain their own TFTP/HTTP/HTTPS server for upgrade and provisioning procedures.

Instructions for local firmware upgrade using TFTP server:

1. Unzip the file and put all of them under the root directory of the TFTP server.
2. Put the PC running the TFTP server and the device in the same LAN segment.
3. Please go to File -> Configure -> Security to change the TFTP server's default setting from "Receive Only" to "Transmit Only" for the firmware upgrade.
4. Start the TFTP server, in the phone's web configuration page
5. Configure the Firmware Server Path with the IP address of the PC
6. Update the change and reboot the unit

End users can also choose to download the free HTTP server from <http://httpd.apache.org/> or use Microsoft IIS web server.

Configuration File Download

Grandstream SIP Device can be configured via Web Interface as well as via Configuration File through TFTP or HTTP/HTTPS. "Config Server Path" is the TFTP or HTTP/HTTPS server path for configuration file. It needs to be set to a valid URL, either in FQDN or IP address format. The "Config Server Path" can be same or different from the "Firmware Server Path".

A configuration parameter is associated with each particular field in the web configuration page. A parameter consists of a Capital letter P and 1 to 3 (Could be extended to 4 in the future) digit numeric numbers. i.e., P2 is associated with "Admin Password" in the ADVANCED SETTINGS page. For a detailed parameter list, please refer to the corresponding firmware release configuration template.

When Grandstream Device boots up or reboots, it will issue request for configuration file named "cfgxxxxxxxxxxxx.xml", where "xxxxxxxxxxxx" is the MAC address of the device, i.e., "cfg000b820102ab.xml". The configuration file name should be in lower cases.

Currently GXV3672_HD/FHD only support XML configuration.

RESTORE FACTORY DEFAULT SETTING

WARNING!

Restoring the Factory Default Setting will DELETE all configuration information of the camera. Please BACKUP or PRINT out all the settings before approach to following steps. Grandstream will not take any responsibility if you lose all the parameters of setting or cannot connect to your VoIP service provider.

Reset from Web Interface

This page allows user to configure dynamic network related parameters:

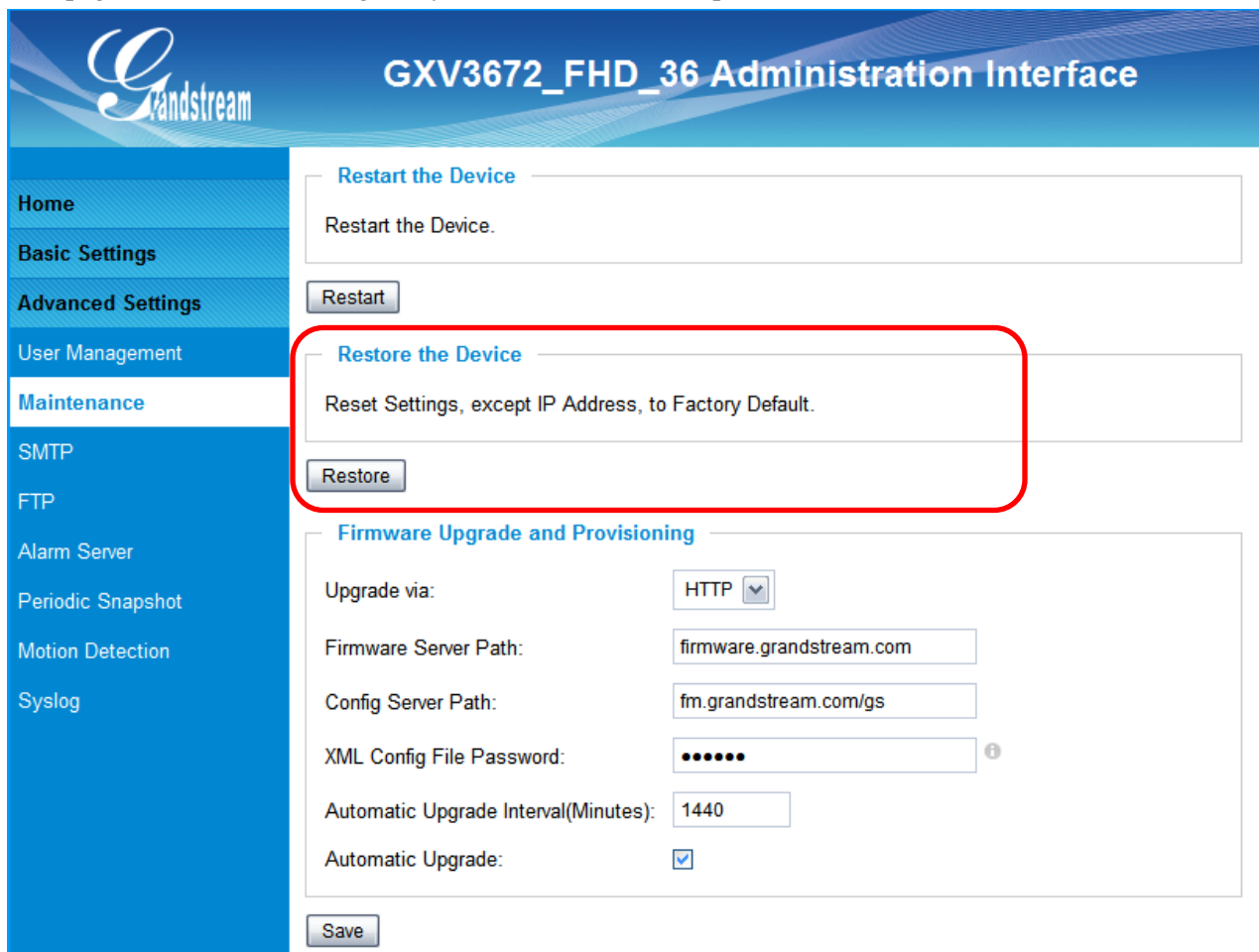

The screenshot displays the 'GXV3672_FHD_36 Administration Interface' with a left-hand navigation menu. The 'Maintenance' menu item is selected. The main content area is divided into three sections: 'Restart the Device', 'Restore the Device', and 'Firmware Upgrade and Provisioning'. The 'Restore the Device' section, which contains the text 'Reset Settings, except IP Address, to Factory Default.' and a 'Restore' button, is highlighted with a red rectangular box. The 'Firmware Upgrade and Provisioning' section includes fields for 'Upgrade via' (set to HTTP), 'Firmware Server Path' (firmware.grandstream.com), 'Config Server Path' (fm.grandstream.com/gs), 'XML Config File Password' (masked with dots), 'Automatic Upgrade Interval(Minutes)' (1440), and a checked 'Automatic Upgrade' checkbox. A 'Save' button is located at the bottom of the interface.

Figure 19: Factory Reset from Web Interface

IP SURVEILLANCE FAQ

1. What is the default IP address of the GXV3672HD_FHD?

The default IP configuration is DHCP.

2. Why can I not view the live video stream in Microsoft Internet Explorer?

Please double check whether the IE add-on was installed correctly.

Once you log into the GXV3672HD_FHD web interface, Internet Explorer will indicate that this website wants to install the following add-on: 'GSViewer.cab' from Grandstream Networks, Inc. Please install this add-on when prompted by IE.

3. How do you manually uninstall the Grandstream video viewer add-on for IE?

Please follow these steps to uninstall the add-on:

1. Delete the *GSViewerX Control* from *C:\WINDOWS\Downloaded Program Files* directory
2. Delete *GSNetClient.dll*, *GS_Replay.exe*, *GSViewerX.ocx*, *hi_h264dec_w.dll*, *lik_VoiceEngine_dll.dll* and *GSViewerX.inf* from *C:\WINDOWS\system32*

4. Why can't I access the GXV3672HD_FHD web configuration interface?

Q 1: Is your internet service down?

A 1: Connect a PC to the internet to test the connection.

Q 2: Are the PC and the device in different subnets?

A 2: Check the subnet mask and default gateway of the device and PC.

Q 3: Is there a conflict with another IP address?

A 3: Try to change the IP address of the device.

Q 4: Has the HTTP port been changed?

A 4: Contact the administrator of the device for more information.

5. The GXV3672HD_FHD web configuration page is not displayed correctly in IE8 ?

In IE8, Compatibility View might need to be enabled for the GXV3672HD_FHD web configuration page to load properly. To enable compatibility view, open IE8, click *Tools*, *Compatibility View Setting*, and add the GXV3672HD_FHD web configuration pages to the Compatibility View.

6. Why does IE indicate to install Grandstream Video Viewer add-on after a firmware upgrade? The add-on was properly installed before the firmware upgrade process.

New firmware will often upgrade the add-on as well. To watch the live video stream, you must install the newest version of the add-on.

7. How do you watch secondary video stream?

Login to the home page of the GXV3672HD_FHD web GUI, click Play to watch the video stream. To watch a secondary video stream, right click on the video, and select *Secondary Stream* on the pop-up menu. Try reinstalling the Grandstream Viewer add-on for IE if you cannot see the video stream.

8. Why is audio missing from the recorded video when an alarm triggered?

To confirm to outdoor standard of IP66, GXV3672HD_FHD does NOT have microphone installed although it has the interface in its PCB board. That is the reason of no audio.

9. What is DDNS? Is it important for IP surveillance product to have DDNS support?

DDNS is an acronym for Dynamic Domain Name Service. It is important to choose an IP network camera that has DDNS support for dynamic IP addresses. Chances are that the network has a dynamic IP address (which changes with every log on). A DDNS service makes sure that the camera's IP address always matches up to the current server address. DDNS also allows a website to be linked to the IP camera that is constantly updated with the correct information and has a reliable feed.

10. Why is Windows Media Player unable to play the recorded video files?

The GXV3672HD_FHD uses the H.264 video codec. Windows Media Player may lack the proper H.264 decoder to play the recorded video. Please download the Microsoft FFDSHOW H.264 decoder from <http://sourceforge.net/projects/ffdshow-tryout/> and install it.

11. Alarm Triggered Events do not work with Surf_Pro?

Please double check the Alarm Action on your GXV3672HD_FHD. Login to the web GUI of the GXV3672HD_FHD, go to the Motion Detection or Alarm Events page, and make sure option Upload to Alarm Center is checked.

12. Recommended to save the video files in different directories when using GSurf_Pro?

It is better to save video files in different directory to prevent accidental deletion of the recorded files you need.

13. How to use a cell phone to watch the GXV3672HD_FHD video stream?

You must set the video resolution to QCIF to watch the GXV3672HD_FHD video stream from a cell phone. Make sure to set the bit rate to 64kbps to ensure the best video quality.

14. What Smartphone application should I use to view the video?

There are free application and paid version application for this, like: IP Cam Viewer

<http://hit-mob.com/>

15. Why the IP address of the device NOT reset when clicking the “Restore” button?

The GXV3672HD_FHD could be installed in areas that are not easy to access. For example, it could be installed on the roof of a building or the ceiling of an office. This makes it difficult to reinstall the device, therefore the “Restore” function will not clear the IP address.

16. Why can't the live video stream be viewed using a mobile phone or GSurf_Pro after changing the HTTP Port of the device?

Make sure that the RTSP port of the device is set to 2000 plus the HTTP Port number. For example, if the HTTP port is 88, then the RTSP port of the device that you configured on GSurf_Pro or mobile phone should be 2088.

17. Port forwarding

Two ports must be forwarded on your router to watch video from a GXV3672HD_FHD that is located on a private network from a PC in a public network. The web port (HTTP) and the RTSP port. Please make note that the RTSP port number changes according to the web port. If the web port is 80, then the RTSP port is 554. If the web port is not 80, then the RTSP port equals the web port +2000. For example, if the web port is 88, then the RTSP port will be 2088.

17. Tested PC display adapters.

Display Adapter	Test Result
SiS 650/651/740/661 FX/741/760 Series	Works normally
Intel® 82945R Express Chipset Family	Works normally
VIA/S3G UniChrome Pro IGP	Works normally
NIVDIA Geforce 7300GS	Works normally
SiS 661FX	Works normally
SiS Mirage Graphics	Works normally
SiS 661 Series	Works normally
Intel® G33/G31 Express	Works normally
SiS Mirage3 Graphics	Works normally
SiS 661FX/GX Mirage Graphics	Works normally
S3 Graphics ProSavageDDR(Microsoft Corporation)	Works normally
XGI Velari Z7/Z9/Z9S V1.08.12	There is some delay when playing videos.
Intel® 965 Express Chipset Family	Works normally
ATI Mobility Radeon X1300	Works normally
Intel® G45/G43 Express Chipset	Works normally
Mobile Intel 965 Express Chipset Family	Works normally
Mobile Intel® 4 Series Express Chipset Family	Works normally
Mobile Intel® 945GM Express Chipset Family	Works normally
Mobile intel® 915GM/GMS, 910GML Express Chipset Family	Works normally
Intel® G45/G43 Express Chipset	Works normally
ATI Technologies, RAGE XL PCI	This display adapter cannot display videos.